

TITE-LOC - METAL DECK / ISO SUBSTRATE DETAILS

CURB - 1 of 2

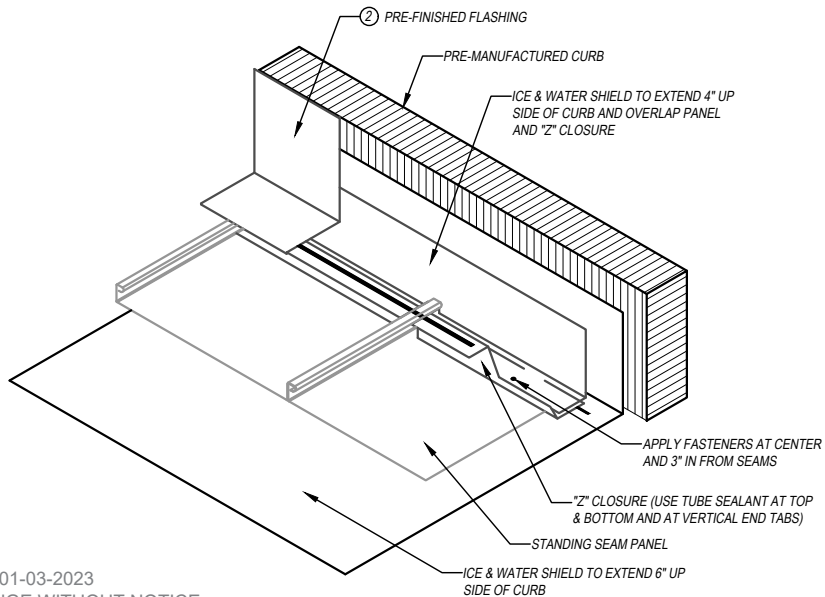
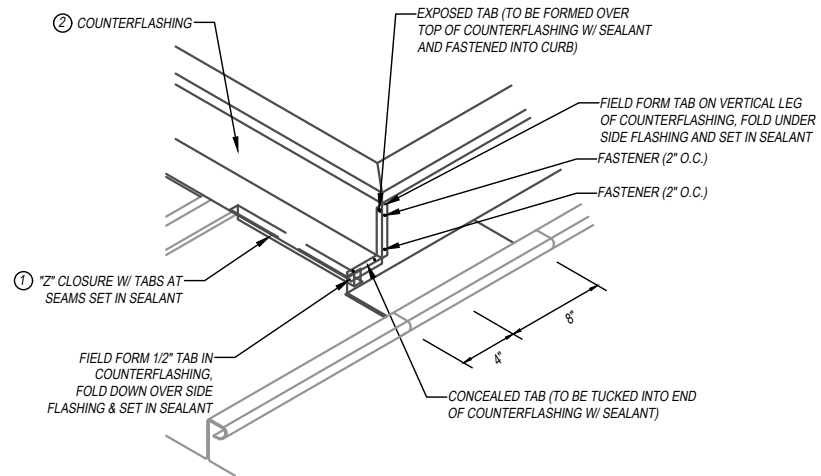
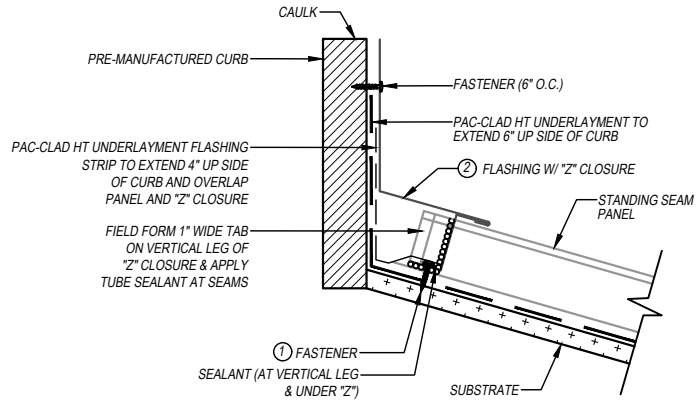
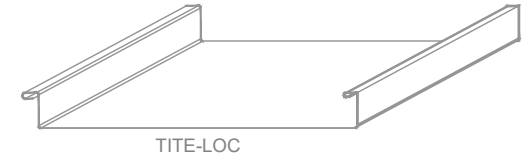

NOTES / LEGEND

ALL FASTENERS DRILLED THROUGH ALUMINUM MUST BE STAINLESS STEEL.

- ① 4 FASTENERS PER PANEL IF PANEL WIDTH < 18"
6 FASTENERS PER PANEL IF PANEL WIDTH = 18"
- ② FLASHING MATERIAL TO MATCH ROOF PANEL MATERIAL.
- ③ MUST BE STAINLESS STEEL IF ROOF PANEL IS ALUMINUM.

KEYNOTES:

- TRIM FASTENERS ARE SELF-DRILL PANCAKE HEAD AND MUST BE INSTALLED IN A STAGGERED PATTERN
- CLIP FASTENERS MUST PENETRATE TOP FLUTE OF METAL DECK SUBSTRATE BY 5/8" MINIMUM THREAD LENGTH

SCALE: NTS
EFFECTIVE DATE: 01-03-2023
SUBJECT TO CHANGE WITHOUT NOTICE

DISCLAIMER: DETAIL SHOWN FOR ILLUSTRATION PURPOSES ONLY. ACTUAL PROJECT DETAIL MAY VARY

TITE-LOC - METAL DECK / ISO SUBSTRATE DETAILS

CURB - 2 of 2

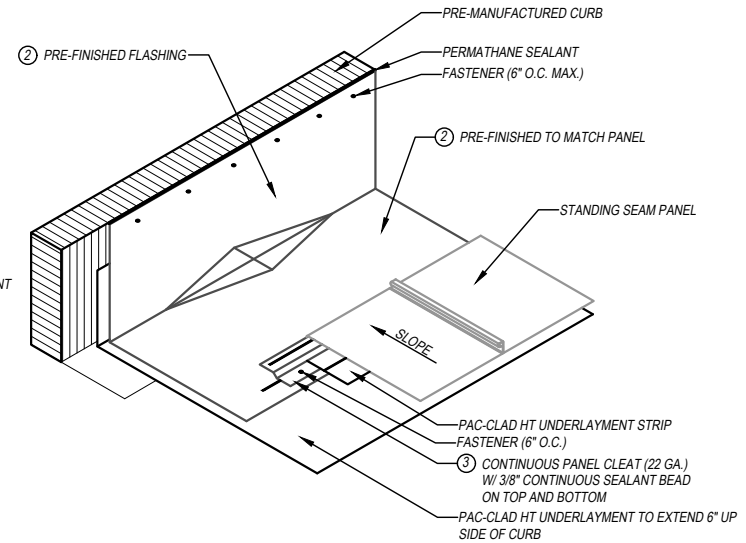
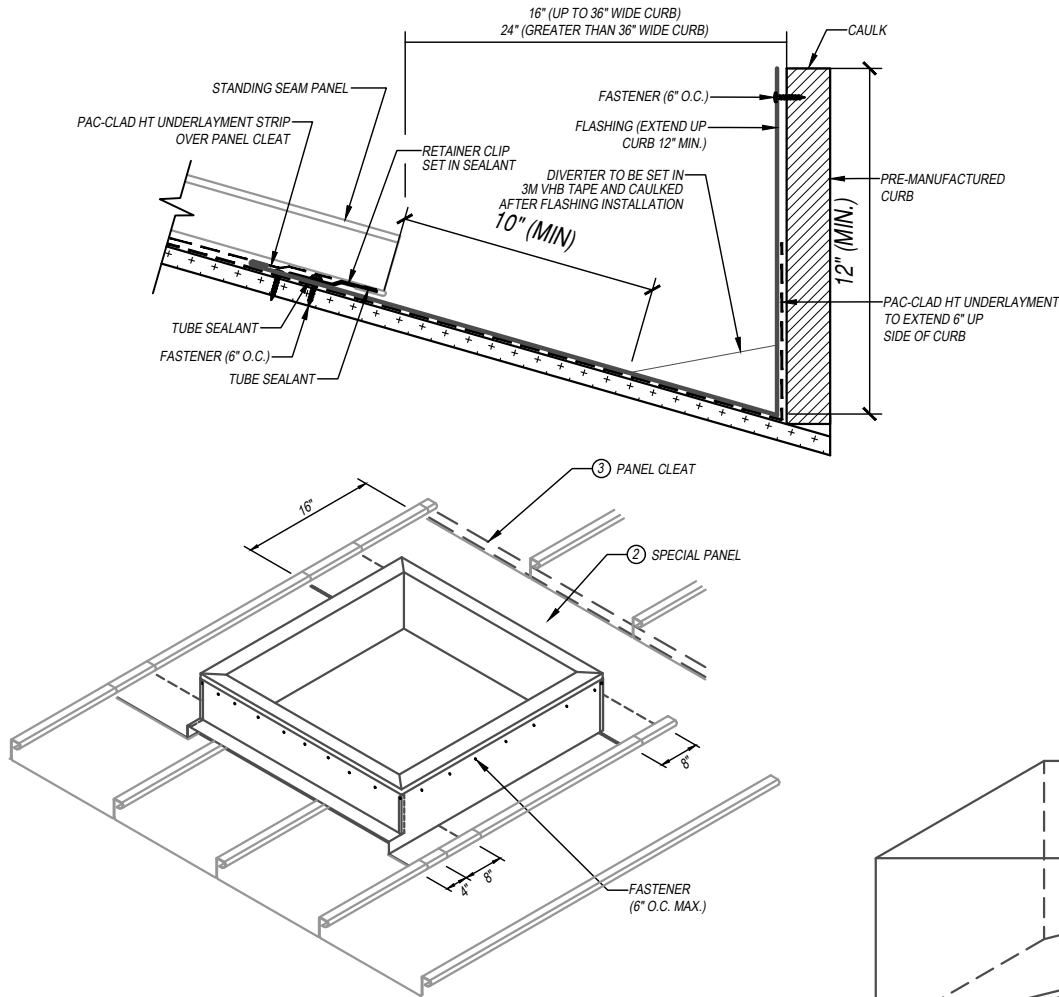
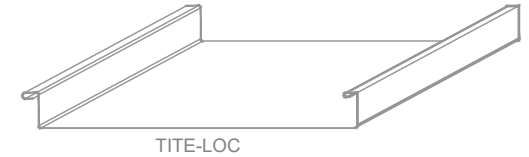

NOTES / LEGEND

ALL FASTENERS DRILLED THROUGH ALUMINUM MUST BE STAINLESS STEEL.

① 4 FASTENERS PER PANEL IF PANEL WIDTH < 18"
6 FASTENERS PER PANEL IF PANEL WIDTH = 18"

② FLASHING MATERIAL TO MATCH ROOF PANEL MATERIAL.

③ MUST BE STAINLESS STEEL IF ROOF PANEL IS ALUMINUM.

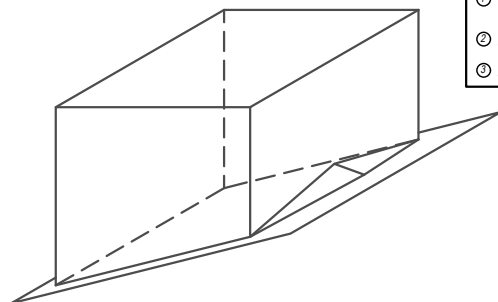

KEYNOTES:

- TRIM FASTENERS ARE SELF-DRILL PANCAKE HEAD AND MUST BE INSTALLED IN A STAGGERED PATTERN
- CLIP FASTENERS MUST PENETRATE TOP FLUTE OF METAL DECK SUBSTRATE BY 5/8" MINIMUM THREAD LENGTH

SCALE: NTS
EFFECTIVE DATE: 01-03-2023
SUBJECT TO CHANGE WITHOUT NOTICE

DISCLAIMER: DETAIL SHOWN FOR ILLUSTRATION PURPOSES ONLY. ACTUAL PROJECT DETAIL MAY VARY