

# COMPOSITE WALL - MODULAR AL - WOOD SUBSTRATE DETAILS

## TOP-OF-WALL DETAIL

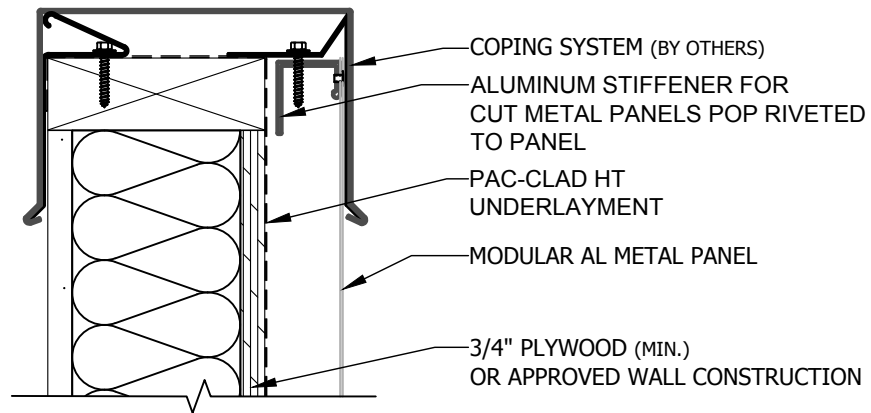

### ACCESSORIES



### ISOMETRIC

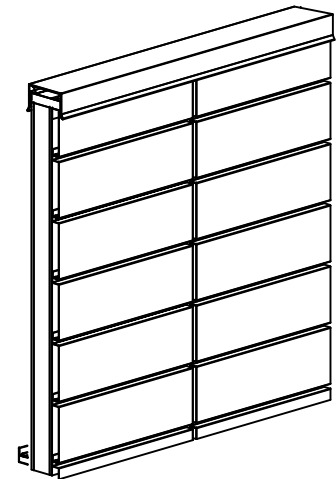

SCALE: 3" = 1'-0"

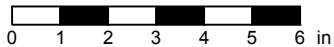

EFFECTIVE DATE: 01-03-2023  
SUBJECT TO CHANGE WITHOUT NOTICE

#### KEYNOTES:

- SHIMS ARE NOT REQUIRED FOR METAL PANELS UNLESS THERE ARE IMPERFECTIONS IN WALL CONSTRUCTION
- IF IMPERFECTIONS, USE HIGH IMPACT PLASTIC SHIMS. (STANDARD WALL CONSTRUCTION DEVIATION IS LESS THAN 1/4" IN 20'-0" IN ALL DIRECTIONS).

DISCLAIMER: DETAIL SHOWN FOR ILLUSTRATION PURPOSES ONLY. ACTUAL PROJECT DETAIL MAY VARY

**PETERSEN ALUMINUM CORPORATION - PAC-CLAD.COM**

**SALES@PETERSENMAIL.COM**

HQ: 1005 Tonne Road  
Elk Grove Village, IL 60007  
P: 800-PAC-CLAD  
F: 800-722-7150

9060 Junction Drive  
Annapolis Junction, MD 20701  
P: 800-344-1400  
F: 301-953-7627

10551 PAC Road  
Tyler, TX 75707  
P: 800-441-8661  
F: 903-581-8592

102 Northpoint Parkway  
Acworth, GA 30102  
P: 800-272-4482  
F: 770-420-2533

1800 S. 7th Ave., Suite 130  
Phoenix, AZ 85007  
P: 833-750-1935  
F: 602-254-6504

9817 233rd Ave. E, Suite A  
Bonney Lake, WA 98391  
P: 253-501-2450  
F: N/A