

PRECISION SERIES - HWP - Z-GIRT
TOP-OF-WALL DETAIL
HORIZONTAL APPLICATION

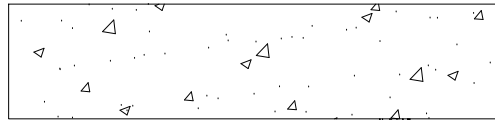

PRECISION SERIES - HWP



*** MAY OMIT SUPPORT PLATE IF ATTACHING TO STRUCTURAL MEMBER**

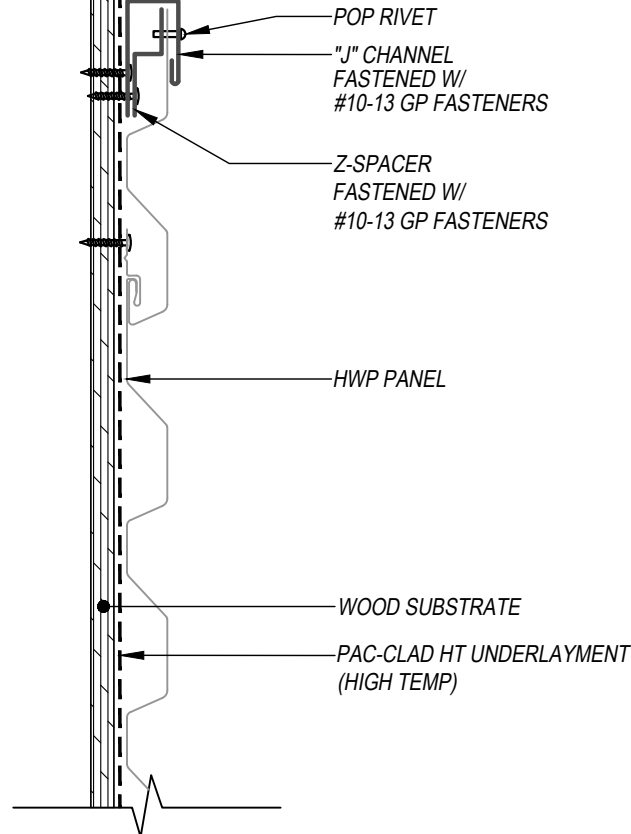

THIS DETAIL DRAWING IS APPLICABLE TO ALL HWP SERIES WALL PANEL PROFILES

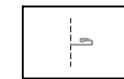
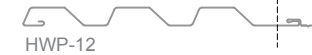

CONCEALED CLIP END

KEYNOTES:

- TRIM FASTENERS ARE SELF-DRILL PANCAKE HEAD AND MUST BE INSTALLED IN A STAGGERED PATTERN
- FASTENERS MUST PENETRATE WOOD SUBSTRATE BY 5/8" MINIMUM THREAD LENGTH
- FASTENER SPACING VARIES BASED ON PROJECT SPECIFIC LOADS AND/OR LOCAL BUILDING CODES

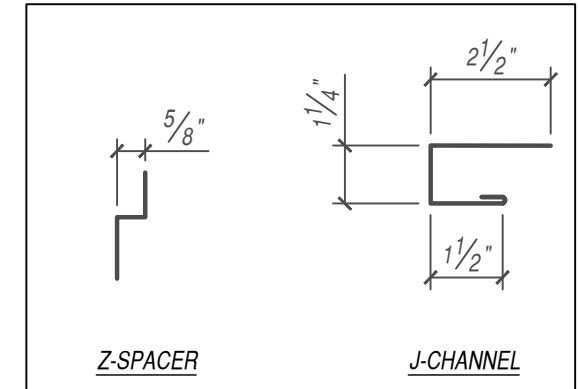

FLASHINGS

SCALE: 3" = 1'-0"

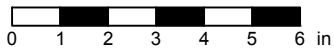

EFFECTIVE DATE: 01-03-2023
SUBJECT TO CHANGE WITHOUT NOTICE

DISCLAIMER: DETAIL SHOWN FOR ILLUSTRATION PURPOSES ONLY. ACTUAL PROJECT DETAIL MAY VARY