

7/8" CORRUGATED - OPEN FRAMING SUBSTRATE DETAILS GUTTER

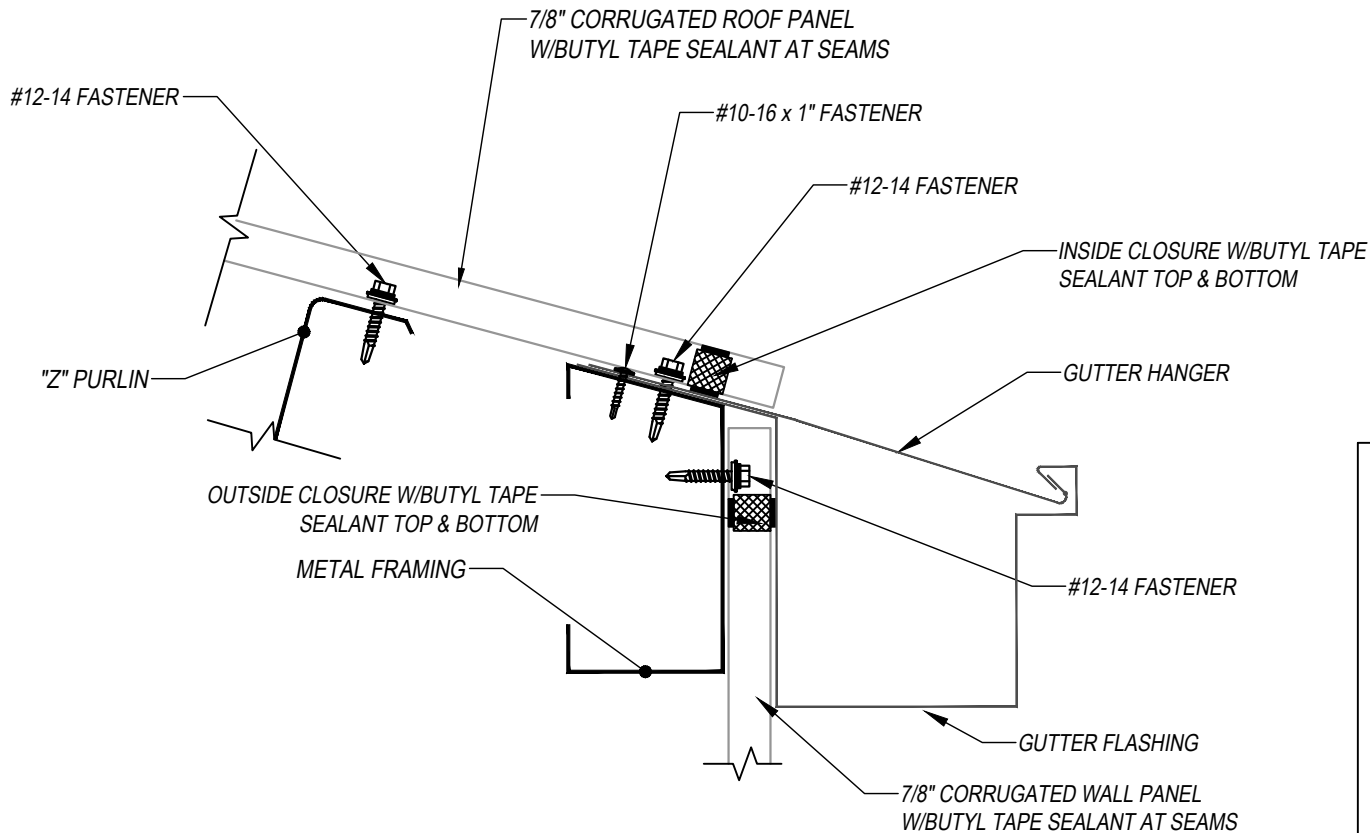

KEYNOTES:

- CLIP FASTENERS MUST PENETRATE TOP FLANGE OF "Z" PURLIN SUBSTRATE BY 5/8" MINIMUM THREAD LENGTH
- CLIP SPACING VARIES BASED ON PROJECT SPECIFIC LOADS AND/OR LOCAL BUILDING CODES
- PANEL TO BE SEAMED 180 DEGREES
- BUTYL TAPE SEALANT USED AT ALL SIDE LAPS WHEN USED AS ROOF PANELS

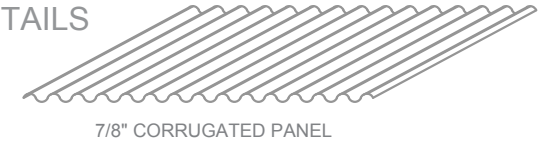
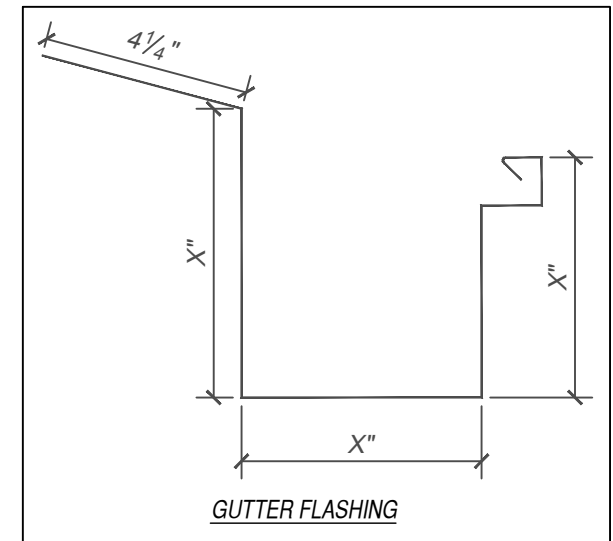

FLASHINGS

SCALE: 3" = 1'-0"



EFFECTIVE DATE: 01-03-2023
SUBJECT TO CHANGE WITHOUT NOTICE

DISCLAIMER: DETAIL SHOWN FOR ILLUSTRATION PURPOSES ONLY. ACTUAL PROJECT DETAIL MAY VARY