

PAC-TITE GOLD COPING

TAPERED

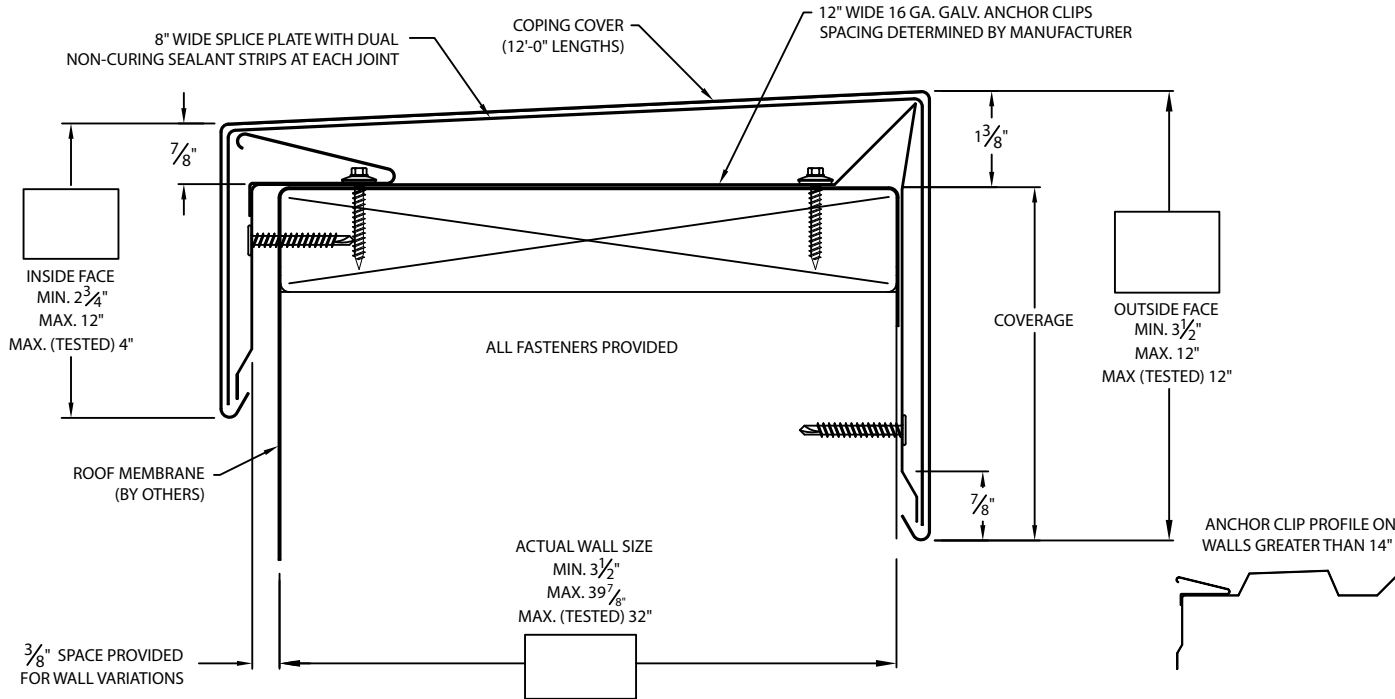

* NOTES

- Oil canning can occur on larger face heights and wall widths; recommend 22 Ga., .050" or .063" Aluminum for face height over 8" or wall width over 12".
- 24 ga. Galv and .040" Aluminum coping covers available for wall sizes of 3.5" to 24" ONLY
- Unless otherwise noted, fabrication of miters and accessories are furnished standard utilizing a non-penetrating quicklock joint, then factory sealed watertight.
- Welded accessories require a minimum material thickness of .050" Aluminum
- For non-90 miters, see separate print approval
- Product should be installed per provided installation instructions
- ANSI/SPRI/FM 4435/ES-1 test pressures up to 297 psf (Horizontal) and 513 psf (Vertical)

PROJECT INFO

Project Name: _____

Architect: _____

Roofing Contractor: _____

APPROVALS*

ANSI/SPRI/FM 4435/ES-1
Test Pressures listed in notes



MATERIAL*

- 24 Ga. Galv. Steel
 - 22 Ga. Galv. Steel
 - .040" Aluminum
 - .050" Aluminum
 - .063" Aluminum
 - OTHER: _____
- Color: _____
- Finish: _____
- Substrate: (For Top Fasteners)
- Wood
 - Masonry
 - Metal
- if substrate is not given, wood fasteners will be provided.

QUANTITIES

_____ Lineal Feet (12'-0" Lengths)

_____ Outside Miter (90°)

_____ Inside Miter (90°)

_____ Right Endcaps

_____ Left Endcaps

Accessory Type* : Quicklock (Default) Welded (Surcharge)

_____ Right Endwall Flashing (Coping Version)

_____ Left Endwall Flashing (Coping Version)

_____ Right Endwall Flashing (Splice Plate Version)

_____ Left Endwall Flashing (Splice Plate Version)

Project Type:

By selecting this box you have verified and confirmed that dimensions, sizes, and quantities are correct. All products will be installed in strict accordance with printed instructions.

Date: _____

Petersen Aluminum Corporation
Phone: 800-323-1960
Fax: 800-722-7150
www.pac-clad.com
e-mail: info@pac-clad.com

SHT# 1 of 2

DATE: 12/9/22

DRN BY: JJC

CKD BY: MM

DWG #: 41011-33127

REV: C

PAC-TITE GOLD COPING

STANDARD ACCESSORIES

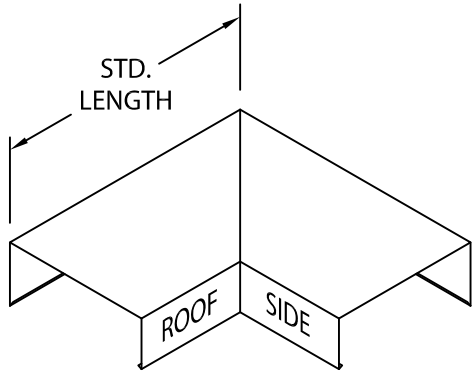

OUTSIDE MITER

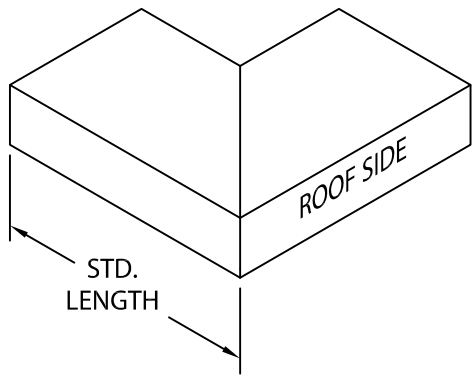

INSIDE MITER

MITER STANDARD LEG LENGTH:
WALL SIZE + 10 1/8" = LENGTH

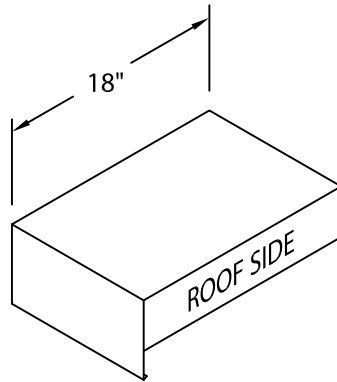

ENDCAP
(LEFT HAND SHOWN)

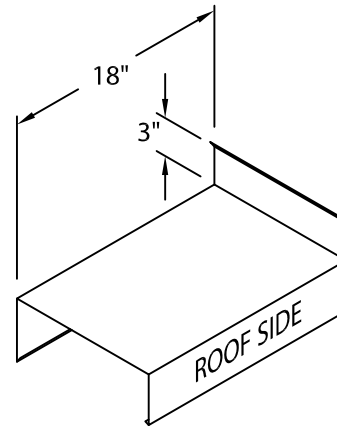

ENDWALL FLASHING
COPING VERSION
(RIGHT HAND SHOWN)

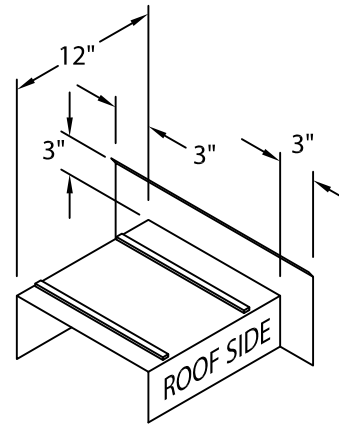

ENDWALL FLASHING
SPLICE PLATE VERSION
(RIGHT HAND SHOWN)
(AVAILABLE ONLY IN
.040" WELDED, PAINTED
TO MATCH COPING)

NOTES

Additional accessories are available including:

- Transition Miters
- Straight Transition Miters
- "T" Miters
- "Z" Miters
- Step-up Miters
- Peak / Valley Miters
- Pilaster Caps
- Radius Coping
- Arched Coping

For additional accessory requirements, attach sketches or call manufacturer for assistance.

SHT# 2 of 2

DATE: 12/9/22

DRN BY: JJC

CKD BY: MM

DWG #: 41011-33127

REV: C

Petersen Aluminum Corporation

Phone: 800-323-1960

Fax: 800-722-7150

www.pac-clad.com

e-mail: info@pac-clad.com