



● Compliance with International Codes  
● Compliance with State Codes

# ICC-ES Evaluation Report

## ESR-4173

Reissued September 2021

This report is subject to renewal September 2023.

**DIVISION: 07 00 00—THERMAL AND MOISTURE PROTECTION**

**Section: 07 41 13—Metal Roof Panels**

**REPORT HOLDER:**

**PETERSEN ALUMINUM CORPORATION**

**EVALUATION SUBJECT:**

**PETERSEN STANDING SEAM METAL ROOF PANELS: SNAP-CLAD, TITE-LOC, TITE-LOC PLUS AND PAC-150 180° SINGLE LOCK**

**1.0 EVALUATION SCOPE**

**Compliance with the following codes:**

- 2018, 2015 and 2012 *International Building Code*® (IBC)
- 2018, 2015 and 2012 *International Residential Code*® (IRC)

**Properties evaluated:**

- Fire classification
- Wind uplift resistance

**Attributes verified:**

See Section 3.1

**2.0 USES**

Petersen Standing Seam Metal Roof Panels are used as roof coverings and are recognized for use as Class A roof coverings when installed in accordance with this report.

**3.0 DESCRIPTION**

**3.1 General:**

Petersen Standing Seam Metal Roof Panels are available in preformed standing seam profiles produced from steel, aluminum, and copper sheet. Materials used in panel fabrication conform to the following specifications:

Aluminum: ASTM B209; minimum 0.032-inch-thick (0.81 mm);  $F_y$  = minimum 21 ksi.

Galvanized Steel: ASTM A653 G90; minimum No. 24 gauge [0.024-inch-thick (0.61 mm)];  $F_y$  = minimum 50 ksi.

Galvalume® Steel: ASTM A792 AZ50; minimum No. 24 gauge [0.024-inch-thick (0.61 mm)];  $F_y$  = minimum 50 ksi.

Copper: ASTM B370; minimum 16 oz./sq. ft. (0.0416 kg/m<sup>2</sup>);  $F_y$  = minimum 38 ksi.

The panel profiles are as follows:

**3.1.1 Snap-Clad:** Formed to 10-inch- to 18-inch-wide (254 mm to 457 mm) panels, with 1<sup>3</sup>/<sub>4</sub>-inch-high (44 mm) snap locking seams. See Figure 1.

**3.1.2 Tite-Loc:** Formed to 12-inch- to 18-inch-wide (305 mm to 457 mm) panels, with 2-inch-high (51 mm) seams that are mechanically locking at 90 degrees. See Figure 2.

**3.1.3 Tite-Loc Plus:** Formed to 12-inch- to 18-inch-wide (305 mm to 457 mm) panels, with 2-inch-high (51 mm) seams that are mechanically locking at 180 degrees. See Figure 3.

**3.1.4 PAC-150 180° Single Lock:** Formed to 12-inch- to 20-inch-wide (305 mm to 508 mm) panels, with 1<sup>1</sup>/<sub>2</sub>-inch-high (38 mm) mechanically locking seams. See Figure 4.

**3.2 Roof Deck:**

Solid or closely fitted decking must be minimum <sup>15</sup>/<sub>32</sub>-inch-thick (11.9 mm) plywood or lumber sheathing, or non-veneer APA rated minimum <sup>7</sup>/<sub>16</sub>-inch-thick (11.1 mm) oriented-strand board (OSB) complying with IBC Section 2304.7.2 or IRC Section R803, or minimum No. 22 gauge [0.030 inch thick (0.76 mm)] steel complying with IBC Section 2210.1.1.2.

**3.3 Underlayment and Flashing:**

Underlayment must be in accordance with IBC Section 1507.4.5 or IRC Section R905.10.5, as applicable. Flashing must be in accordance with IBC Section 1503.2 or IRC Section R903.2, as applicable.

**3.4 Insulation:**

Foam plastic insulation, where used, must have a flame-spread index of not more than 75 in accordance with ASTM E84 or UL 723 when tested at the maximum thickness intended for use. Polyisocyanurate and polystyrene foam plastic insulation must comply with ASTM C1289 and ASTM C578, respectively. See Tables 1 and 2 for insulations used with specific roof systems.

**3.5 Panel Clips and Bearing Plates:**

Panel clips are fabricated as described below. Dimensional drawings are shown in Figures 5 through 9.

**3.5.1 Snap-Clad Clip:** ASTM A653 G90, minimum No. 18 gauge [0.047-inch-thick (1.19 mm)] galvanized steel; or

300 series stainless steel, minimum No. 18 gauge [0.047-inch-thick (1.19 mm)]. See Figure 5.

**3.5.2 Tite-Loc Sliding AR Clip:** Two-piece clip with tabs consisting of 300 series stainless steel, minimum No. 24 gauge [0.024-inch-thick (0.61 mm)] for use with aluminum panels and ASTM A653 G90, minimum No. 22 gauge [0.03-inch-thick (0.76 mm)] when used with steel panels. The base of the clip is minimum No. 18 gauge [0.047-inch-thick (1.19 mm)]. See Figure 6.

**3.5.3 Tite-Loc Plus AR Clip:** Two-piece clip with tabs consisting of 300 series stainless steel, minimum No. 24 gauge [0.024-inch-thick (0.61 mm)] for use with aluminum panels and ASTM A653 G90, minimum No. 22 gauge [0.03-inch-thick (0.76 mm)] when used with steel panels. The base of the clip is minimum No. 18 gauge [0.047-inch-thick (1.19 mm)]. See Figure 7.

**3.5.4 PAC-150 Clip:** Two-piece clip with tabs consisting of 300 series stainless steel, minimum No. 24 gauge [0.024-inch-thick (0.61 mm)] for use with aluminum panels and ASTM A653 G90, minimum No. 22 gauge [0.03-inch-thick (0.76 mm)] when used with steel panels. The base of the clip is minimum No. 16 gauge [0.03-inch-thick (0.76 mm)]. See Figure 8.

**3.5.5 Bearing Plate:** ASTM A653 G90 or 300 series stainless steel plates with a thickness of No. 20 gauge [0.036-inch-thick (0.91 mm)] or No. 16 gauge [0.054-inch-thick (1.37 mm)] metal and can be used with any of the roof panel clips described in Section 3.5 of this report. See Figure 9.

### 3.6 Fasteners:

Fasteners required for the attachment of metal roof panels, panel clips and bearing plates must be corrosion-resistant and be as specified in the wind resistance table (Table 2) for the specific assemblies.

## 4.0 DESIGN AND INSTALLATION:

### 4.1 General:

Installation of the Petersen standing seam metal roof panels must be in accordance with this report, IBC Section 1507.4 or IRC Section R905.10, as applicable, and the report holder's published installation instructions. The report holder's installation instructions must be available on the jobsite at all times during installation.

The roof panels must be installed on solid or closely fitted decking or steel decking, as specified in Section 3.2 having a minimum roof slope in accordance with Table 3. Penetrations and terminations of the panels must be flashed and made weathertight in accordance with the report holder's published installation instructions and IBC Section 1503.2 or IRC Section R903.2, as applicable.

### 4.2 Fire Classification:

The steel, copper, and aluminum roof panels are components of roof assemblies classified as Class A roof assemblies in accordance with ASTM E108 or UL 790 when installed as specified in Table 1.

Under the IBC and IRC, copper and steel roof panels are considered Class A roof coverings, when installed, without insulation, as described in Section 4.1 of this report on steel roof decks in accordance with Exception 2 to IBC Section 1505.2 and Exception 2 to IRC Section R902.1.

### 4.3 Wind Uplift Resistance:

The allowable wind uplift pressures for Petersen Standing Seam Metal Roof Panels are specified in Table 2.

## 5.0 CONDITIONS OF USE

The Petersen Standing Seam Metal Roof Panels described in this report comply with, or are suitable alternatives to what is specified in, those codes listed in Section 1.0 of this report, subject to the following conditions:

- 5.1 Installation must comply with the applicable code, this report and the report holder's published installation instructions. In the event of conflicts between this report and the report holder's instructions, this report governs.
- 5.2 The metal panels must be installed only by applicators approved by Petersen Aluminum Corporation.
- 5.3 Foam plastic insulation must be separated from the interior of the building by an approved thermal barrier in accordance with IBC Section 2603.4.1.5 or IRC Section R316.4.5.2, as applicable.
- 5.4 Foam plastic insulation, where used, must bear the label of an approved agency indicating that the foam plastic has a flame-spread index of not more than 75 when tested at the maximum thickness intended for use in accordance with ASTM E84 or UL 723, subject to the approval of the code official.
- 5.5 Above-deck thermal insulation must comply with the applicable standard specified in IBC Table 1508.2 or IRC Table R906.2, as applicable.
- 5.6 Design wind uplift pressure on any roof area, including edge and corner zones, must not exceed the allowable wind pressure for the system. Refer to the allowable wind uplift pressure for the metal panels as specified in Table 2.
- 5.7 The allowable wind uplift pressures specified in Table 2 are for the roof covering only. The deck and framing to which the roof covering is attached must be designed for the applicable components and cladding wind loads in accordance with the IBC or IRC, as applicable.
- 5.8 Calculations demonstrating that the required wind resistance is less than the allowable wind resistance must be submitted to the code official.
- 5.9 The panels are manufactured in Phoenix, Arizona, under a quality control program with inspections by ICC-ES.

## 6.0 EVIDENCE SUBMITTED

Data in accordance with the ICC-ES Acceptance Criteria for Metal Roof Coverings (AC166), dated October 2012 (editorially revised January 2018).

## 7.0 IDENTIFICATION

- 7.1 The panels are identified with a label bearing the report holder's name (Petersen Aluminum Corporation), the product name, the material type, and the evaluation report number (ESR-4173).
- 7.2 The report holder's contact information is the following:

**PETERSEN ALUMINUM CORPORATION**  
**1005 TONNE ROAD**  
**ELK GROVE VILLAGE, ILLINOIS 60007**  
**(847) 956-7968**  
[www.pac-clad.com](http://www.pac-clad.com)

TABLE 1—FIRE CLASSIFICATION ASSEMBLIES

SYSTEM NO.	ROOF CLASS	SUBSTRATE <sup>1</sup>	MAX. ROOF SLOPE	ASSEMBLY DETAIL <sup>2,3,4</sup>	
1	A	Noncombustible	Unlimited	<b>Barrier Board:</b>	Georgia-Pacific DensDeck® Roofboard or United States Gypsum Corp. SECUROCK Glass-Matt Roof Board (Type SGMRX, 1/4 in. thick min.
				<b>Ply Sheet (Optional):</b>	Any UL Classified Type G1, G2 or G3 base/ply sheet, Type 15, 20 or 30 felt or equivalent asphalt-based, mechanically attached UL Classified Prepared Roofing Accessory.
				<b>Panel:</b>	Steel or Aluminum Snap-Clad, Tite-Loc, Tite-Loc Plus and PAC-150 180° Single Lock, mechanically fastened.
2	A	Noncombustible	Unlimited	<b>Barrier Board:</b>	Min. 5/8-inch thick plywood.
				<b>Ply Sheet (Optional):</b>	Any UL Classified Type G1, G2 or G3 base/ply sheet, Type 15, 20 or 30 felt or equivalent asphalt-based, mechanically attached UL Classified Prepared Roofing Accessory.
				<b>Panel:</b>	Steel Snap-Clad, Tite-Loc, Tite-Loc Plus and PAC-150 180° Single Lock, mechanically fastened.
3	A	Noncombustible	Unlimited	<b>Barrier Board:</b>	Min. 7/16-inch oriented strand board or min. 5/8-inch plywood over min. 1-inch-thick polyisocyanurate insulation board or min. 1-inch-thick Polyisocyanurate composite board.
				<b>Ply Sheet (Optional):</b>	Any UL Classified Type G1, G2 or G3 base/ply sheet, Type 15, 20 or 30 felt or equivalent asphalt-based, mechanically attached UL Classified Prepared Roofing Accessory.
				<b>Panel:</b>	Steel or Aluminum Snap-Clad, Tite-Loc, Tite-Loc Plus and PAC-150 180° Single Lock, mechanically fastened.
4	A	Noncombustible	Unlimited	<b>Insulation:</b>	Polyisocyanurate, glass fiber, perlite or wood fiber, minimum 1-inch-thick.
				<b>Ply Sheet (Optional):</b>	Any UL Classified Type G1, G2 or G3 base/ply sheet, Type 15, 20 or 30 felt or equivalent asphalt-based, mechanically attached UL Classified Prepared Roofing Accessory.
				<b>Panel:</b>	Steel or Aluminum Snap-Clad, Tite-Loc, Tite-Loc Plus and PAC-150 180° Single Lock, mechanically fastened.
5	A	Noncombustible	Unlimited	<b>Framing:</b>	Metal purlins
				<b>Panel:</b>	Steel Snap-Clad, Tite-Loc, Tite-Loc Plus and PAC-150 180° Single Lock, mechanically fastened.
6	A	Combustible	Unlimited	<sup>5</sup> <b>Barrier Board:</b>	Georgia-Pacific DensDeck® Roofboard <sup>4</sup> or United States Gypsum Corp. SECUROCK Glass-Matt Roof Board (Type SGMRX)G-P Products “DensDeck®”, 1/4 in. thick min. with all joints staggered a minimum of 6 inches from the plywood joints.
				<b>Ply Sheet (Optional):</b>	Any UL Classified Type G1, G2 or G3 base/ply sheet, Type 15, 20 or 30 felt or equivalent asphalt-based, mechanically attached UL Classified Prepared Roofing Accessory.
				<b>Panel:</b>	Steel or Aluminum Snap-Clad, Tite-Loc, Tite-Loc Plus and PAC-150 180° Single Lock, mechanically fastened.

For SI: 1 inch = 25.4 mm.

<sup>1</sup>Wood deck must be a minimum of 15/32-inch-thick (11.9 mm) plywood or non-veneer APA-rated 7/16-inch-thick (11.1 mm) oriented-strand board (OSB). Steel deck must be a minimum of No. 22 gauge galvanized steel [0.030 inch (0.76 mm)].

<sup>2</sup>All foam plastic insulation must be UL-classified foam plastic for roofing systems, and must be limited to the minimum thickness noted and the maximum thickness for which the flame spread index (in accordance with ASTM E84 or UL 723) is 75 or less. Polyisocyanurate foam plastic insulation must comply with ASTM C1289 and wood fiber board must comply with ASTM C208.

<sup>3</sup>Barrier or cover boards, ply sheets, underlayments, and panels must be UL-classified for roofing systems.

<sup>4</sup>The optional ply sheet may be any roofing underlayment recognized for use with classified roof coverings in a current ICC-ES evaluation report as complying with the ICC-ES Acceptance Criteria for Roof Underlayments (AC188).

<sup>5</sup>For System No. 6, one or more layers of GAF “VersaShield® Fire Resistant Roof Deck Protection” or “VersaShield™ Underlayment” (ESR-2053), mechanically attached or loose laid, may be used in lieu of barrier board when installed directly underneath the metal panels.

TABLE 2—WIND RESISTANCE ASSEMBLIES

SYSTEM NO.	DECK <sup>1</sup>	INSULATION <sup>2,3</sup>	BARRIER OR COVER BOARD <sup>6,8</sup>	UNDER-LAYMENT	PANEL		ALLOWABLE UPLIFT PRESSURE (psf)
					TYPE	ATTACHMENT <sup>3, 4, 5</sup>	
W-1	<sup>19</sup> / <sub>32</sub> -inch Plywood or <sup>5</sup> / <sub>8</sub> -inch OSB <sup>9</sup>	N/A	N/A	See Section 3.3	Min. 0.032" aluminum Tite-Loc (max. 18-inch wide)	Tite-Loc Sliding Clip at 30 inches o.c. attached with two #10-12 x 1-inch Pancake Head screws	127
W-2	<sup>19</sup> / <sub>32</sub> -inch Plywood or <sup>5</sup> / <sub>8</sub> -inch OSB <sup>9</sup>	N/A	N/A	See Section 3.3	Min. No. 24 gauge steel Tite-Loc (max. 18-inch wide)	Tite-Loc Sliding Clip at 48 inches o.c. for plywood or at 30 inches o.c. for OSB attached with two #14 x 1 <sup>1</sup> / <sub>4</sub> -inch Pancake Head screws	37
W-3	<sup>19</sup> / <sub>32</sub> -inch Plywood <sup>9</sup>	N/A	N/A	See Section 3.3	Min. 16 <sup>oz</sup> / <sub>sf</sub> eighth-hard copper Snap-Clad (max. 16-inch wide)	Stainless steel Snap-Clad Clip at 24 inches o.c. with two #10-16 x 1-inch stainless steel pancake Head screws	45
W-4	<sup>5</sup> / <sub>8</sub> -inch Plywood <sup>9</sup>	N/A	N/A	See Section 3.3	Min. 0.032" aluminum PAC-150 180° Single Lock (max. 20-inch wide)	PAC-150 Clip at 36 inches o.c. with two <sup>1</sup> / <sub>4</sub> -13 x 1 <sup>5</sup> / <sub>8</sub> -inch screws	45
W-5	<sup>5</sup> / <sub>8</sub> -inch Plywood <sup>9</sup>	N/A	N/A	See Section 3.3	Min. No. 24 gauge steel PAC-150 180° Single Lock (max. 16-inch wide)	PAC-150 Clip at 36 inches o.c. with two <sup>1</sup> / <sub>4</sub> -13 x 1 <sup>5</sup> / <sub>8</sub> -inch screws	45
W-6	<sup>19</sup> / <sub>32</sub> -inch Plywood <sup>10</sup>	(Optional) Any rigid insulation, 1 <sup>1</sup> / <sub>2</sub> -inch max. thickness, with a minimum 25 psi compressive strength or minimum 2 PCF density	N/A	See Section 3.3	Min. No. 24 gauge steel Snap-Clad (max. 18-inch wide)	Snap-Clad Clip at 36 inches o.c. with two 10-12 x 1-inch Pancake Head screws or No. 12 Dekfast fastener when rigid insulation and bearing plates are used	45
W-7	<sup>19</sup> / <sub>32</sub> -inch Plywood <sup>9</sup>	N/A	N/A	See Section 3.3	Min. 0.032-inch aluminum Tite-Loc or Tite-Loc Plus (max. 18-inch wide)	Tite-Loc Plus AR or Tite-Loc AR Sliding Clip at 30 inches o.c. with two 10-12 x 1-inch Pancake Head screws	45
W-8	Min. <sup>15</sup> / <sub>32</sub> -inch Plywood <sup>10</sup>	(Optional) Foamed plastic insulation, max. 10-inch-thick	(Optional Cover Board) Min. <sup>1</sup> / <sub>2</sub> -inch-thick plywood, <sup>7</sup> / <sub>16</sub> -inch thick OSB, <sup>1</sup> / <sub>2</sub> -inch gypsum board, <sup>1</sup> / <sub>2</sub> -inch wood fiberboard, <sup>1</sup> / <sub>4</sub> -inch G-P Gypsum DensDeck, <sup>1</sup> / <sub>4</sub> -inch USG "SECUROCK Glass Mat Board" or <sup>1</sup> / <sub>4</sub> -inch "SECUROCK Roof Board"	(Optional) See Section 3.3	Min. 0.032 aluminum Snap-Clad (max. 16-inch wide)	Snap-Clad Clip at 18 inches o.c. with two 10-12 x 1-inch Pancake Head screws	45
W-9	<sup>5</sup> / <sub>8</sub> -inch Plywood or OSB <sup>10</sup>	None	None	None	Min. 24 gauge steel Tite-Loc or Tite-Loc Plus (max. 16-inches wide)	Tite-Loc AR Sliding Clip or Tite-Loc Plus AR Sliding Clip at 60 inches o.c. with two 10 x 1-inch Pancake Head wood screws	45

TABLE 2—WIND RESISTANCE ASSEMBLIES (Continued)

SYSTEM NO.	DECK <sup>1</sup>	INSULATION <sup>2,3</sup>	BARRIER OR COVER BOARD <sup>6,8</sup>	UNDER-LAYMENT	PANEL		ALLOWABLE UPLIFT PRESSURE (psf)
					TYPE	ATTACHMENT <sup>3, 4, 5</sup>	
W-10	Min. 11/2-inch thick closely spaced wood decking	(Optional) Foamed plastic insulation, min. 1-inch thick and min. 2 pcf density	None	None	Min. 24 gauge steel Tite-Loc or Tite-Loc Plus (max. 16-inches wide)	Tite-Loc AR Sliding Clip or Tite-Loc Plus AR Sliding Clip at 24 inches o.c. with two 10 x 1-inch Pancake Head wood screws	45
W-11	<sup>19</sup> / <sub>32</sub> -inch Plywood or <sup>5</sup> / <sub>8</sub> -OSB <sup>8</sup>	None	None	None	Min. 24 gauge steel Tite-Loc or Tite-Loc Plus (max. 18-inches wide)	Tite-Loc AR Sliding Clip or Tite-Loc Plus AR Sliding Clip at 48 inches o.c. with two No. 14 <sup>1</sup> / <sub>4</sub> x 1-inch Pancake Head wood screws	45
CF-1	Min. 5-inch thick cement fiber board with foamed plastic core with a <sup>7</sup> / <sub>16</sub> -inch OSB facing <sup>10</sup>	None	None	None	Min. 24 gauge steel Tite-Loc or Tite-Loc Plus (max. 16-inches wide)	Tite-Loc AR Sliding Clip or Tite-Loc Plus AR Sliding Clip at 24 inches o.c. with two No. 14 <sup>1</sup> / <sub>4</sub> x <sup>1</sup> / <sub>4</sub> -inch screws	45
CF-2	Min. 5-inch thick cement fiber board with foamed plastic core with a <sup>7</sup> / <sub>16</sub> -inch OSB facing <sup>10</sup>	1-inch min. to 3 <sup>1</sup> / <sub>2</sub> -inch max., 2.0 PCF polyisocyanurate foamed plastic with a factory laminated <sup>7</sup> / <sub>16</sub> -inch-thick OSB	(Optional) max. <sup>5</sup> / <sub>8</sub> -inch-thick gypsum cover board	Section 3.3	Min. 0.032 aluminum Snap-Clad (max. 16-inches wide)	Snap-Clad Clip at 18 inches o.c. with two No. 10-12 x 1-inch Pancake Head screws	45
CF-3	Min. 5-inch thick cement fiber board with foamed plastic core with a <sup>7</sup> / <sub>16</sub> -inch OSB facing <sup>10</sup>	1-inch min. (3 <sup>1</sup> / <sub>2</sub> -inch max.) 2.0 PCF polyisocyanurate foamed plastic with a factory laminated <sup>7</sup> / <sub>16</sub> -inch-thick OSB	(Optional) max. <sup>5</sup> / <sub>8</sub> -inch-thick gypsum cover board	Section 3.3	Min. 24 gauge steel Snap-Clad (max. 18-inch wide)	Snap-Clad Clip at 36 inches o.c. with two No. 10-12 x 1-inch Pancake Head screws	45
S-1	Steel Framing (Min. 0.056-inch thickness) at max. 48 inches o.c.	None	N/A	N/A	Min. 24 gauge steel Snap-Clad (max. 12-inches wide)	Snap-Clad Clip at 48 inches o.c. with two No. 10-16 x 1-inch self-drilling, self-tapping Pancake Head screws	45
S-2	Steel Framing (Min. 0.056-inch thickness) at max. 60 inches o.c.	None	N/A	N/A	Min. 22 gauge steel Snap-Clad (max. 12-inches wide)	Snap-Clad Clip at 60 inches o.c. with two No. 10-16 x 1-inch self-drilling, self-tapping Pancake Head screws	45
S-3	Steel Framing (Min. 0.056-inch thickness) at max. 48 inches o.c.	None	N/A	N/A	Min. 24 gauge steel Snap-Clad (max. 18-inches wide)	Snap-Clad Clip at 48 inches o.c. with two No. 14-13 Pancake Head screws (length to penetrate steel framing min. <sup>5</sup> / <sub>8</sub> -inch)	45
S-4	Steel Framing (Min. 0.056-inch thickness) at max. 60 inches o.c.	None	N/A	N/A	Min. 24 gauge steel Snap-Clad (max. 18-inches wide)	Snap-Clad Clip at 60 inches o.c. with two No. 10-16 x 1-inch self-drilling, self-tapping Pancake Head screws	30
S-5	Steel Framing (Min. 0.054-inch thickness) at max. 36 inches o.c.	None	N/A	N/A	Min. 0.032 aluminum Snap-Clad (max. 10 <sup>1</sup> / <sub>2</sub> -inches wide)	Snap-Clad Clip at 36 inches o.c. with two No. 10-16 x 1-inch self-drilling, self-tapping Pancake Head screws	45

TABLE 2—WIND RESISTANCE ASSEMBLIES (Continued)

SYSTEM NO.	DECK <sup>1</sup>	INSULATION <sup>2,3</sup>	BARRIER OR COVER BOARD <sup>6,8</sup>	UNDER-LAYMENT	PANEL		ALLOWABLE UPLIFT PRESSURE (psf)
					TYPE	ATTACHMENT <sup>3,4,5</sup>	
S-6	Steel Framing (Min. 0.056-inch thickness) at max. 48 inches o.c.	None	N/A	N/A	Min. 0.032 aluminum Snap-Clad (max. 10 <sup>1</sup> / <sub>2</sub> -inches wide)	Snap-Clad Clip at 48 inches o.c. with two No. 10-16 x 1-inch self-drilling, self-tapping Pancake Head screws	30
S-7	Steel	Foamed plastic Insulation (1-inch-thick min., 4 <sup>1</sup> / <sub>2</sub> -inch thick max.) with a min. density of 1.8 PCF	N/A	N/A	Min. 24 gauge steel Snap-Clad (max. 18-inches wide)	Snap-Clad Clip at 48 inches o.c. with two No. 14 self-drilling screws (length to penetrate steel decking min. <sup>3</sup> / <sub>4</sub> -inch)	45
S-8	Steel	Rigid Insulation (1-inch-thick min., 4 <sup>1</sup> / <sub>2</sub> -inch thick max.) with a min. density of 1.8 PCF	N/A	N/A	Min. 0.032 aluminum Snap-Clad (max. 16-inches wide)	Snap-Clad Clip at 48 inches o.c. with two No. 14 self-drilling screws (length to penetrate steel decking min. <sup>3</sup> / <sub>4</sub> -inch)	45
S-9	Steel	1-inch min. (3 <sup>1</sup> / <sub>2</sub> -inch max.) 2.0 PCF polyisocyanurate foamed plastic with a factory laminated <sup>7</sup> / <sub>16</sub> -inch thick OSB	(Optional) <sup>5</sup> / <sub>8</sub> -inch thick gypsum cover board	Section 3.3	Min. 0.032 aluminum Snap-Clad (max. 16-inches wide)	Snap-Clad Clip at 18 inches o.c. with two No. 10-12 x 1-inch Pancake Head screws	45
S-10	Steel	1-inch min. (3 <sup>1</sup> / <sub>2</sub> -inch max.) 2.0 PCF polyisocyanurate foamed plastic with a factory laminated <sup>7</sup> / <sub>16</sub> -inch thick OSB	(Optional) <sup>5</sup> / <sub>8</sub> -inch thick gypsum cover board	Section 3.3	Min. 24 gauge steel Snap-Clad (max. 18-inch wide)	Snap-Clad Clip at 36 inches o.c. with two No. 10-12 x 1-inch Pancake Head screws	45
S-11	Steel	1-inch min. (6-inch max.) polyisocyanurate foamed plastic with a factory laminated <sup>7</sup> / <sub>16</sub> -inch thick OSB	(Optional barrier board) Max. <sup>5</sup> / <sub>8</sub> -inch thick GP DensDeck Roofboard	Section 3.3	Min. 0.032 aluminum Snap-Clad (max. 16-inches wide)	Snap-Clad Clip at 18 inches o.c. with two No. 10-12 x 1-inch Pancake Head screws	45
S-12	Steel	1-inch min. (6-inch max.) polyisocyanurate foamed plastic with a factory laminated <sup>7</sup> / <sub>16</sub> -inch thick OSB	(Optional barrier board) Max. <sup>5</sup> / <sub>8</sub> -inch thick GP DensDeck Roofboard	Section 3.3	Min. 24 gauge steel Snap-Clad (max. 18-inches wide)	Snap-Clad Clip at 36 inches o.c. with two No. 10-12 x 1-inch Pancake Head screws	45
S-13	Steel Framing (Min. 0.056-inch thickness) at max. 60 inches o.c.	(Optional) Max. 6-inch fiberglass blanket insulation	N/A	N/A	Min. 24 gauge steel Tite-Loc or Tite-Loc Plus (max. 16-inches wide)	Tite-Loc AR Sliding Clip or Tite-Loc Plus AR Sliding Clip at each purlin with two No. 12-14 x 1-inch or <sup>1</sup> / <sub>4</sub> -14 x 1-inch self-drilling screw	45
S-14	Steel Framing (Min. 0.056-inch thickness) at max. 60 inches o.c.	Foamed plastic Insulation (1-inch-thick min., 3-inch thick max.)	N/A	N/A	Min. 24 gauge steel Tite-Loc or Tite-Loc Plus (max. 16-inches wide)	Tite-Loc AR Sliding Clip or Tite-Loc Plus AR Sliding Clip at each purlin with two No. 12-14 x 1-inch or <sup>1</sup> / <sub>4</sub> -14 x 1-inch self-drilling screw	45
S-15	Steel	(Optional) Foamed plastic Insulation, min. 1-inch thick with a min. compressive strength of 25 psi or density of 2.0 pcf	(Optional) <sup>3</sup> / <sub>8</sub> -inch thick OSB roof cover board and/or <sup>5</sup> / <sub>8</sub> -inch thick gypsum barrier board <sup>8</sup>	N/A	Min. 24 gauge steel Tite-Loc or Tite-Loc Plus (max. 16-inches wide)	Tite-Loc AR Sliding Clip or Tite-Loc Plus AR Sliding Clip at 48 inches o.c. with two No. 12-14 x 1-inch self-drilling screw (length to penetrate steel decking min. <sup>1</sup> / <sub>2</sub> -inch)	45

TABLE 2—WIND RESISTANCE ASSEMBLIES (Continued)

SYSTEM NO.	DECK <sup>1</sup>	INSULATION <sup>2,3</sup>	BARRIER OR COVER BOARD <sup>6,8</sup>	UNDER-LAYMENT	PANEL		ALLOWABLE UPLIFT PRESSURE (psf)
					TYPE	ATTACHMENT <sup>3, 4, 5</sup>	
S-16	Steel Framing (Min. 0.068-inch thickness) at max. 60 inches o.c.	(Optional) Max. 6-inch fiberglass blanket insulation	N/A	N/A	Min. 24 gauge steel Tite-Loc or Tite-Loc Plus (max. 16-inches wide)	Tite-Loc AR Sliding Clip or Tite-Loc Plus AR Sliding Clip at 60 inches o.c. with two No. 12 x 1-inch self-drilling screw	45
S-17	Steel	None	Min. 1/2-inch gypsum board	None	Min. 24 gauge steel Tite-Loc or Tite-Loc Plus (max. 16-inches wide)	Tite-Loc AR Sliding Clip or Tite-Loc Plus AR Sliding Clip at 48 inches o.c. with two No. No. 14 self-drilling screw (length to penetrate steel decking min. 1/2-inch)	45
S-18	Steel	(Optional) Min. 13/16-inch expanded polystyrene with a min. density of 1.0 pcf	Min. 1/2-inch gypsum board	None	Min. 24 gauge steel Tite-Loc or Tite-Loc Plus (max. 16-inches wide)	Tite-Loc AR Sliding Clip or Tite-Loc Plus AR Sliding Clip at 48 inches o.c. with two No. No. 14 self-drilling screw (length to penetrate steel decking min. 1/2-inch)	45

For SI: 1 inch = 25.4 mm; 1 ft = 0.305 m; 1 psf = 47.88 Pa.

<sup>1</sup>Wood deck must be a minimum 15/32-inch-thick (11.9 mm) plywood or non-veneer APA-rated minimum 7/16-inch-thick (11.1 mm) oriented-strand board (OSB), unless otherwise noted in this report. Steel deck must be a minimum No. 22 gauge galvanized steel [0.030 inch (0.76 mm)].

<sup>2</sup>All foam plastic insulation must be UL-classified foam plastic for roofing systems, and must be limited to the maximum thickness for which the flame spread index (in accordance with ASTM E84 or UL 723) is 75 or less. Polyisocyanurate foam plastic insulation must comply with ASTM C1289 and polystyrene foam plastic insulation must comply with ASTM C578.

<sup>3</sup>All installations over foam plastic insulation require use of the Bearing Plate. Bearing plates may be eliminated if system includes an OSB cover board. Systems W-6, W-8 and W-10 require the use of a 16 gauge bearing plate.

<sup>4</sup>Fastener spacing is the maximum allowable for the rated pressure.

<sup>5</sup>Minimum penetration through the deck for fasteners is 1 inch for wood decks and 3/4 inch for steel decks.

<sup>6</sup>Optional barrier board to be minimum 7/16-inch-thick OSB installed with HD Hailgard Fasteners at a rate of 24 per 4 ft x 8 ft board, where applicable.

<sup>7</sup>Steel framing used for panel attachment must be minimum 50 ksi.

<sup>8</sup>All joints in wood sheathing shall be sealed with 1-inch wide urethane caulk (Bostik Chem) cured for 16 hours. The sheathing must be attached to supports with 2 1/2-inch long drywall screws spaced at 6 inches around the perimeter and 12 inches in the field of the sheets. The entire deck is then covered with an asphalt-saturated felt per the report holder's installation instructions.

<sup>9</sup>Plywood attachment to supports shall consist of No. 8-18 by 1 7/8 inch long screws or 8d x 2 1/2 inch long deformed shank common nails spaced at 6 inches o.c. at the plywood edges and 12 inches o.c. in the field.

<sup>10</sup>UL classified structural cement fiber units Tectum Inc. (ESR-1112) "Type E Panel" or "Type III Panel."

TABLE 3—MINIMUM ROOF SLOPES

PANEL	MINIMUM SLOPE
Snap-Clad	2:12 (17-percent)
Tite-Loc	1/2:12 (4-percent)
Tite-Loc Plus	1/2:12 (4-percent)
PAC-150 180° Single Lock	1/2:12 (4-percent)



FIGURE 1—SNAP-CLAD

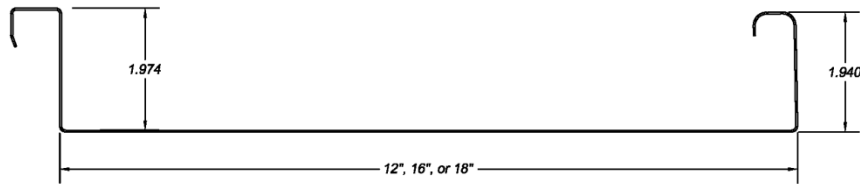

FIGURE 2—TITE-LOC

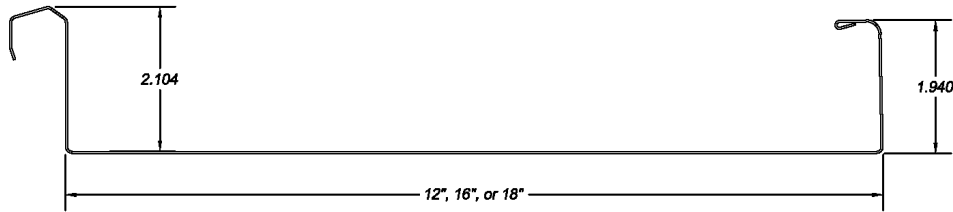

FIGURE 3—TITE-LOC PLUS

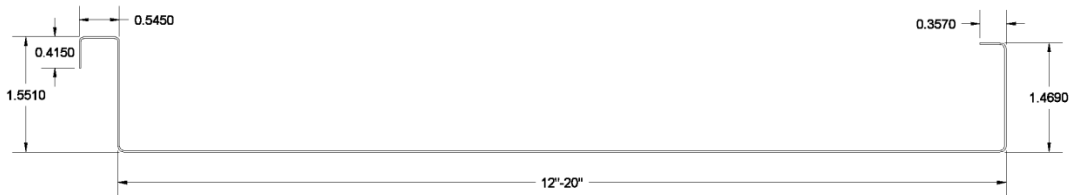

FIGURE 4—PAC-150 180° SINGLE LOCK



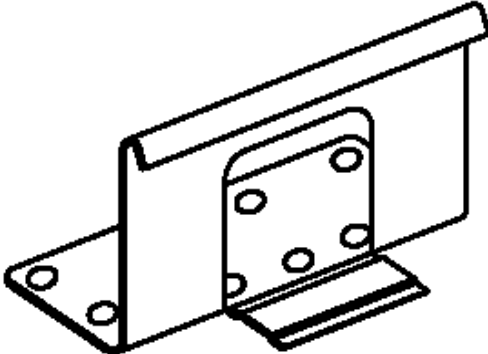

FIGURE 5—SNAP-CLAD CLIP

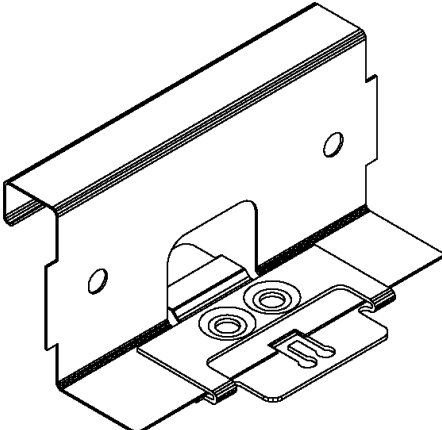

FIGURE 6—TITE-LOC AR CLIP

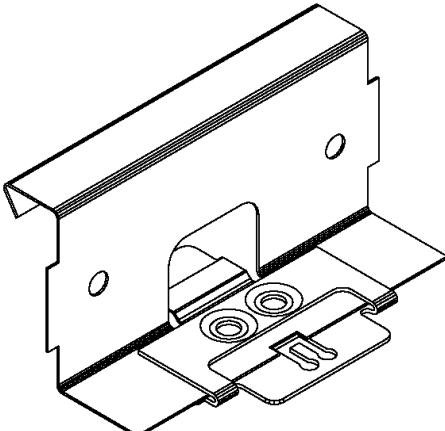

FIGURE 7—TITE-LOC PLUS AR CLIP

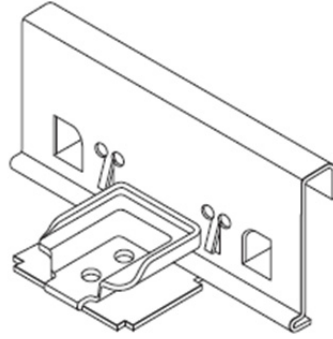

FIGURE 8—PAC-150 CLIP

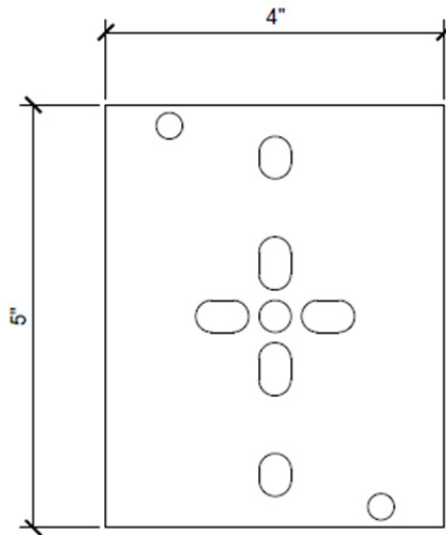

FIGURE 9—BEARING PLATE

**DIVISION: 07 00 00—THERMAL AND MOISTURE PROTECTION**  
**Section: 07 41 13—Metal Roof Panels**

**REPORT HOLDER:****PETERSEN ALUMINUM CORPORATION****EVALUATION SUBJECT:****PETERSEN STANDING SEAM METAL ROOF PANELS: SNAP-CLAD, TITE-LOC, TITE-LOC PLUS AND PAC-150 180° SINGLE LOCK****1.0 REPORT PURPOSE AND SCOPE****Purpose:**

The purpose of this evaluation report supplement is to indicate that Petersen Standing Seam Metal Roof Panels, described in ICC-ES evaluation report ESR-4173, has also been evaluated for compliance with the codes noted below.

**Applicable code edition(s):**

- 2016 *California Building Code* (CBC)
- 2016 *California Residential Code* (CRC)

**2.0 CONCLUSIONS****2.1 CBC:**

The Petersen Standing Seam Metal Roof Panels, described in Sections 2.0 through 7.0 of the evaluation report ESR-4173, is a Class A roof covering complying with CBC Section 1505.1.1, a Class B roof covering complying with CBC Section 1505.1.2, or a Class C roof covering complying with CBC Section 1505.1.3, provided the design and installation are in accordance with the 2015 *International Building Code*® (IBC) provisions noted in the evaluation report.

**2.2 CRC:**

The Petersen Standing Seam Metal Roof Panels, described in Sections 2.0 through 7.0 of the evaluation report ESR-4173, may be used where the CRC requires a Class A roof covering complying with CRC Section R902.1.1, a Class B roof covering complying with CRC Section R902.1.2, or a Class C roof covering complying with CRC Section R902.1.3, provided the design and installation are in accordance with the 2015 *International Residential Code*® (IRC) provisions noted in the evaluation report and the additional requirements of CRC Sections R905.4.

This supplement expires concurrently with the master report, reissued September 2021.