



## Farabaugh Engineering and Testing Inc.

Project No. T149-19

Report Date: March 19, 2019

Total Pages: 26 pages (inclusive)

**ASTM E 1592**  
STANDARD TEST METHOD FOR  
STRUCTURAL PERFORMANCE OF SHEET METAL ROOF AND SIDING SYSTEMS  
BY UNIFORM STATIC AIR PRESSURE DIFFERENCE

ON

**T-PANEL - METAL ROOF PANEL**  
**16" WIDE X 0.032" ALUMINUM**  
**WITH CONTINUOUS CLIPS AND INTERMITTENT CLIPS**  
**(5 SPANS @ 5'-0" O.C. & 12 SPANS @ 2'-0" O.C.)**

FOR

PETERSEN ALUMINUM CORP.  
10551 PAC ROAD  
TYLER, TX. 75707

Report Prepared By:

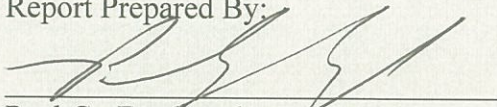
  
Paul G. Farabaugh

Reviewed and Approved By:

  
Daniel G. Farabaugh

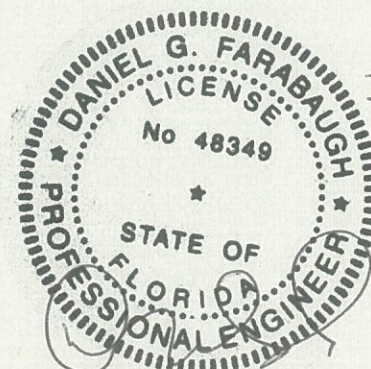

DANIEL G. FARABAUGH, P.E.  
255 Saunders Station Rd.  
Trafford, PA 15085  
(412) 373-9238

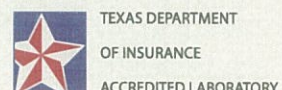

Project No. T149-19

**ASTM E1592-05**  
**STANDARD TEST METHOD FOR**  
**STRUCTURAL PERFORMANCE OF SHEET METAL ROOF AND SIDING SYSTEMS**  
**BY UNIFORM STATIC AIR PRESSURE DIFFERENCE**

**Purpose**

This test method covers the evaluation of the structural performance of Sheet Metal Panels and Anchor to Panel Attachments for roof or siding systems under uniform static air pressure difference.

**Test Date**

3/11/19 Test #1 - 5 Spans @ 5'-0" o.c. with intermittent clips  
3/18/19 Test #2 - 5 Spans @ 5'-0" o.c. with continuous clips  
3/15/19 Test #3 - 12 Spans @ 2'-0" o.c. with intermittent clips  
3/19/19 Test #4 - 12 Spans @ 2'-0" o.c. with continuous clips

**Test Specimen**

Manufacturer: Petersen Aluminum  
10551 PAC Rd.  
Tyler, TX. 75707

Panel: T-PANEL - Metal Roof Panel, 16" wide x 0.032" aluminum with 0.032" alum. cap

Intermittent Clip: 6" wide x 16 ga. galvanized steel clip

Continuous Clip: 120" wide x 16 ga. galvanized steel clip

**Testing Apparatus**

A test chamber was used with two static pressure taps located at diagonally opposite corners. A controlled blower provided a uniformly load the specimen mock-up. Calibrated manometers were used to measure the pressure at each pressure tap. The uniform load pressure was performed in the negative direction to monitor wind uplift on the panel specimen mock-up. Calibrated deflectometers were attached to monitor panel deformation as shown.

### **Installation**

- The panels were installed on to 16 ga supports with using (2) #14-13 X 1-1/2" long, DP1, Concealor, self-drill fasteners per intermittent/continuous clip at supports. Test #1 & Test #3 used intermittent clips and Test #2 & #4 used continuous clips. Additional screw was used at each end of a continuous clip. The panel sidejoints used a 0.032" aluminum seam cap and were seamed with a mechanical seamer. The seam cap used 2 beads of factory sealant, one bead on each side of cap corners. The panel ends were fastened with (5) 1/4-14 x 1-1/2 long, self-drill, hex head fasteners with washer. The outer side panels were fastened with (2)1/4-14 x 1-1/2" long self- drill, hex head fasteners with washer at each support along each side of the mock-up.
- Plastic (4 mil thick) was employed loosely between the panels and subgirts and in the side joints to create a vacuum seal.

### **Procedure**

- The specimen was checked for proper adjustment and all vents closed in the pressure measuring lines.
- The required deflection measuring apparatus were installed at their specified locations.
- A nominal initial pressure was applied equal to at least four times but not more than ten times the dead weight of the specimen. This nominal pressure was used as the reference zero and initial deflection readings were recorded.
- At each load increment, pressure was maintained for a period of not less than 60 seconds and until the deflection gages indicated no further increase in deflections.
- Successive increments were achieved as above until failure or ultimate load was reached.

The test was conducted according to the procedure in ASTM E-1592-05 and as noted herein. In our opinion the tape and plastic had no influence on the results of the test.

Project No. T149-19

## TEST #1

Specimen: T-PANEL - Metal Roof Panel, 16" wide x 0.032" aluminum with intermittent Clip

Clip Spacing: 5 ft o/c

### NEGATIVE (UPLIFT) PRESSURE

PETERSEN ALUM. T-PANEL 16" WIDE X 0.032" ALUMINUM (5 SPANS @ 5' O.C.) INTERMITTENT CLIP

LOAD (PSF)	DEFLECTION DIAL READINGS (INCHES)					
	D-1	D-2	D-3	D-4	D-5	D-6
0.0	0.000	0.000	0.000	0.000	0.000	0.000
10.4	0.092	0.467	0.067	0.531	0.044	0.752
0.0	0.020	0.056	0.034	0.076	0.022	0.064
20.8	0.192	2.584	0.188	2.589	0.105	2.454
0.0	0.036	0.099	0.050	0.160	0.029	0.107
31.2	0.302	3.220	0.298	3.183	0.151	3.092
0.0	0.066	0.222	0.071	0.199	0.037	0.168
41.6	0.445	3.787	0.452	3.696	0.204	3.652
0.0	0.091	0.228	0.097	0.220	0.030	0.187
52.0	0.627	4.445	0.690	4.304	0.269	4.307
0.0	0.130	0.299	0.144	0.289	0.035	0.223

### RESULTS:

Load held for 1 minute = 57.2 psf

Maximum Test Load = 59.3 psf (Buckled at end span across all panels)

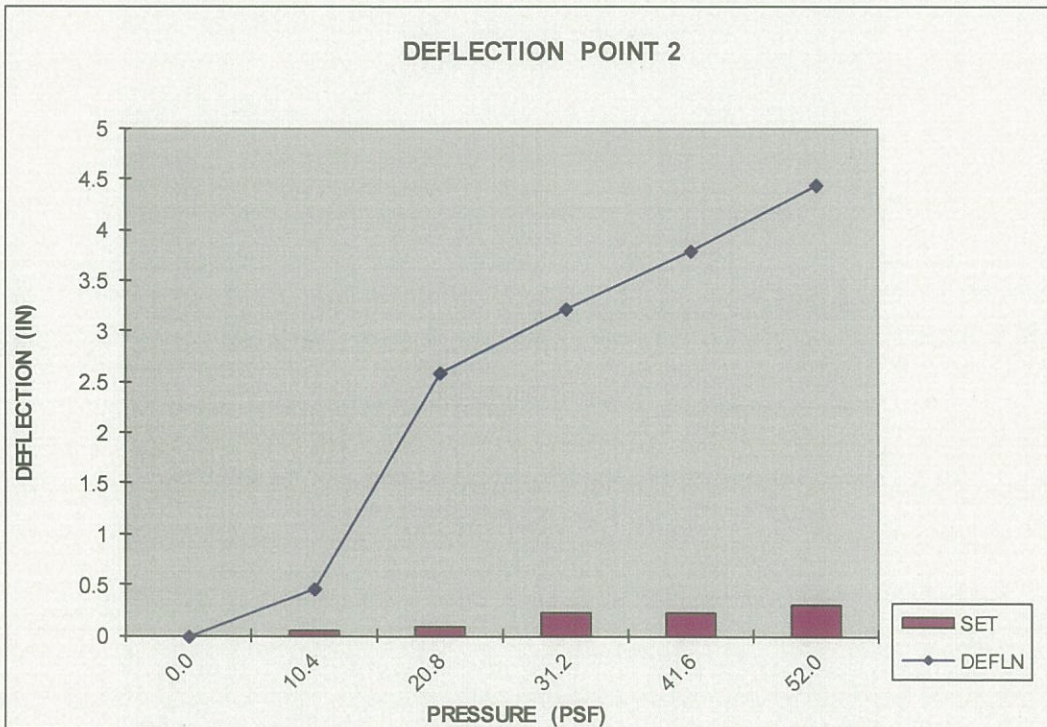
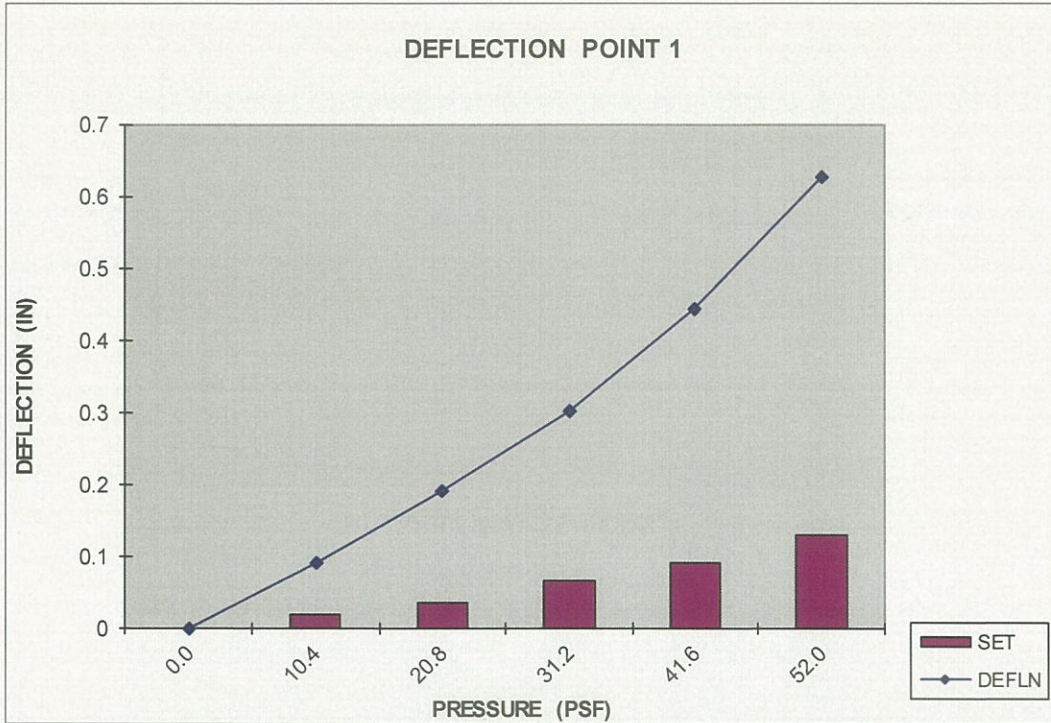

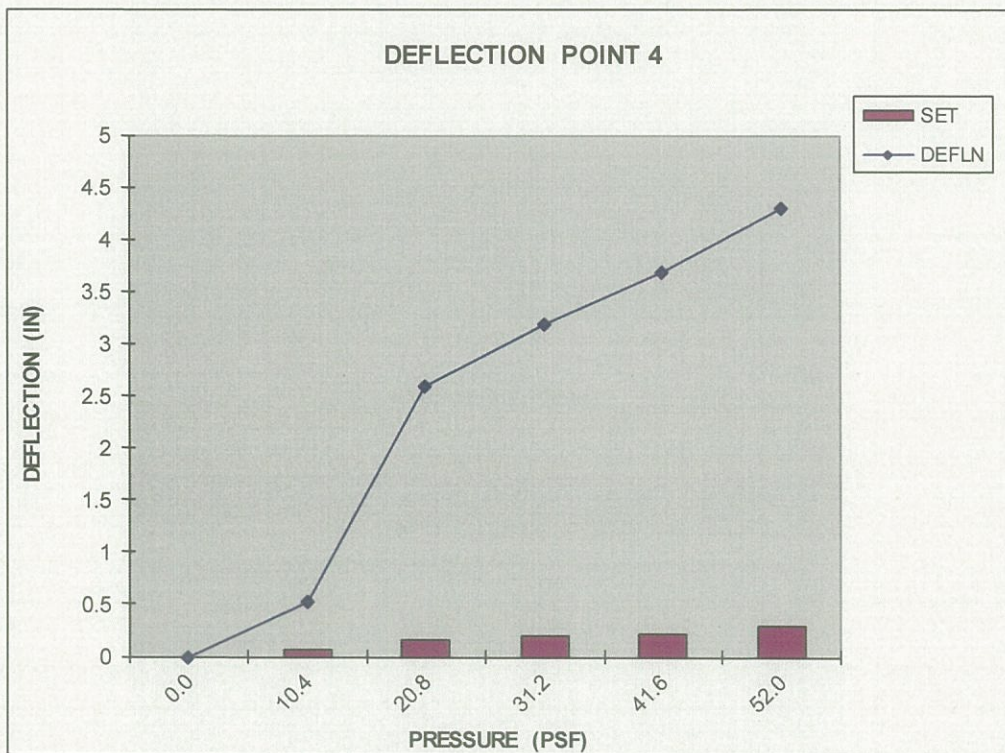
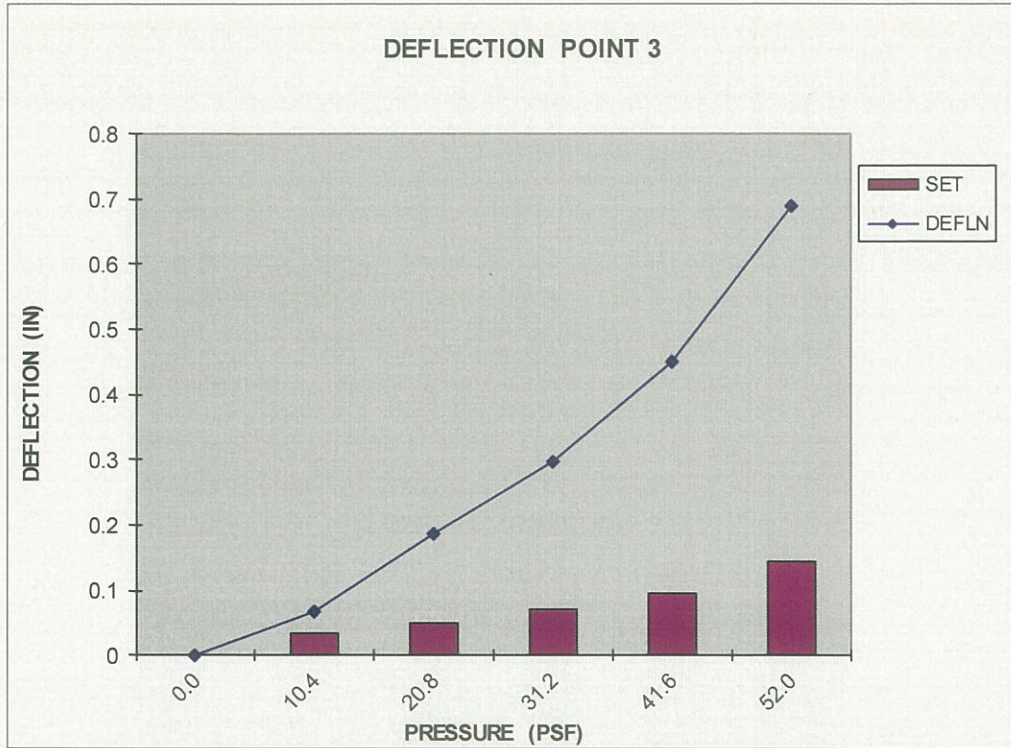

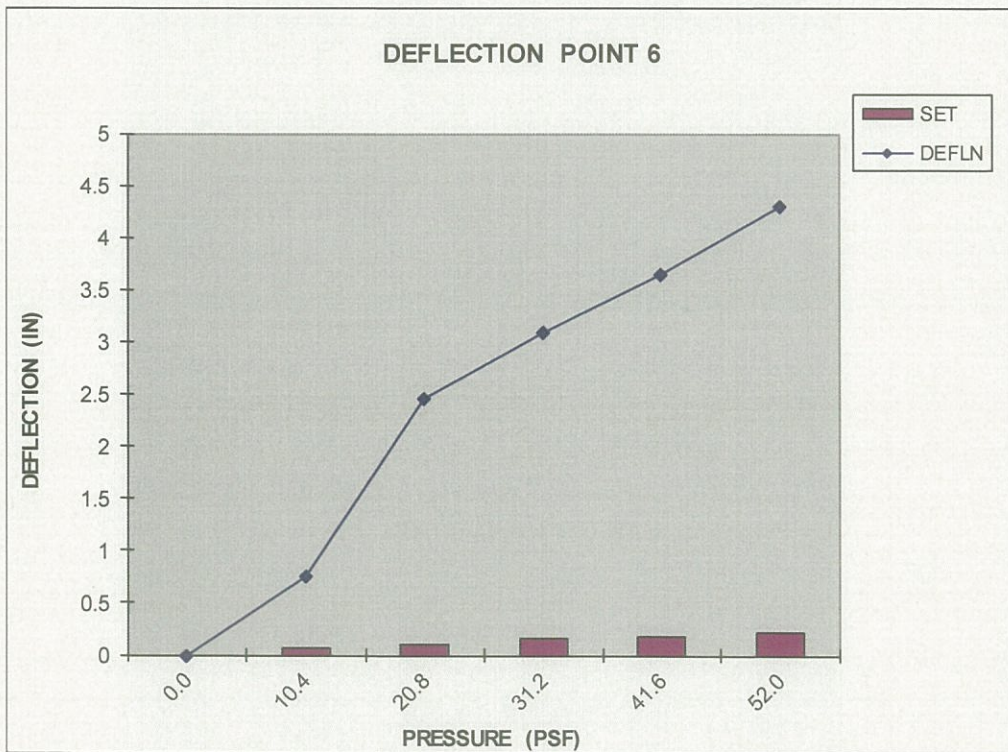
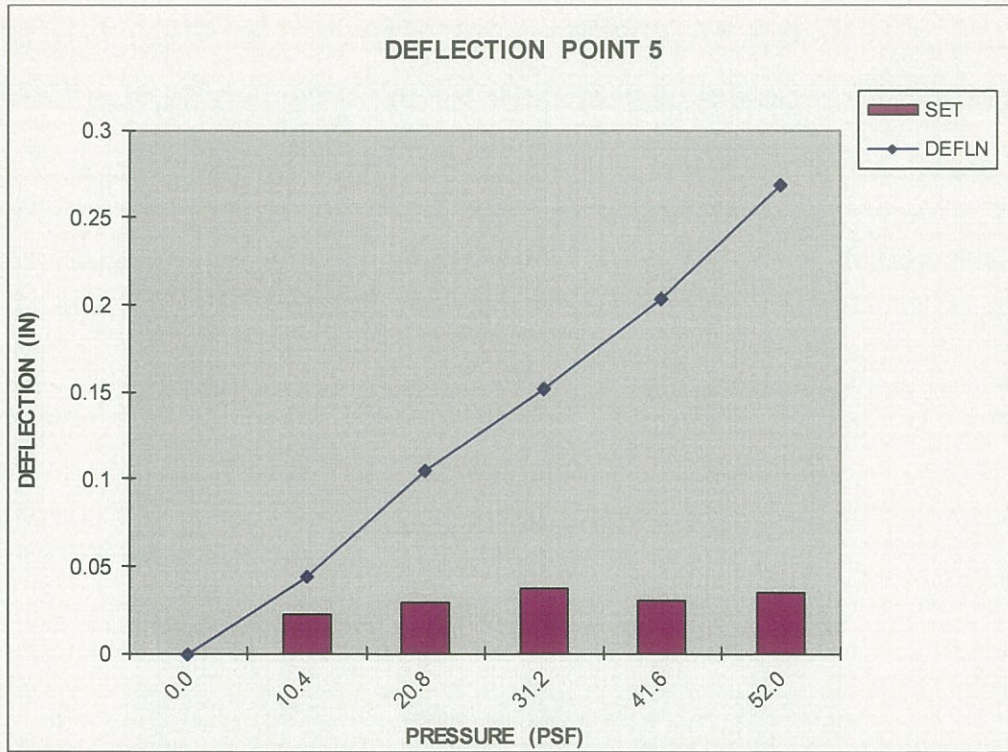

Project No. T149-19

## TEST #2

Specimen: T-PANEL - Metal Roof Panel, 16" wide x 0.032" aluminum with continuous Clip

Clip Spacing: 5 ft o/c

### NEGATIVE (UPLIFT) PRESSURE

PETERSEN ALUM. T-PANEL 16" WIDE X 0.032" ALUM. (5 SPANS @ 5' O.C.) CONT. CLIP

LOAD (PSF)	DEFLECTION DIAL READINGS (INCHES)					
	D-1	D-2	D-3	D-4	D-5	D-6
0.0	0.000	0.000	0.000	0.000	0.000	0.000
15.6	0.032	1.523	0.034	1.552	0.033	1.381
0.0	0.001	0.017	0.001	0.017	0.001	0.021
31.2	0.071	2.262	0.079	2.275	0.073	2.093
0.0	0.005	0.025	0.008	0.023	-0.002	0.016
46.8	0.111	2.702	0.125	2.709	0.112	2.521
0.0	0.010	0.045	0.018	0.049	0.003	0.033
62.4	0.151	3.083	0.177	3.083	0.158	2.897
0.0	0.021	0.094	0.038	0.079	0.017	0.091
78.1	0.190	3.449	0.233	3.493	0.196	3.252
0.0	0.041	0.187	0.062	0.222	0.031	0.168
93.7	0.236	3.848	0.293	3.899	0.241	3.635
0.0	0.075	0.563	0.111	1.799	0.061	0.467
109.3	0.284	4.226	0.360	4.275	0.303	4.029
0.0	0.111	2.395	0.158	2.675	0.102	2.103

### RESULTS:

Load held for 1 minute = 156 psf

Maximum Test Load = 157 psf (clip fastener pulled thru clip)



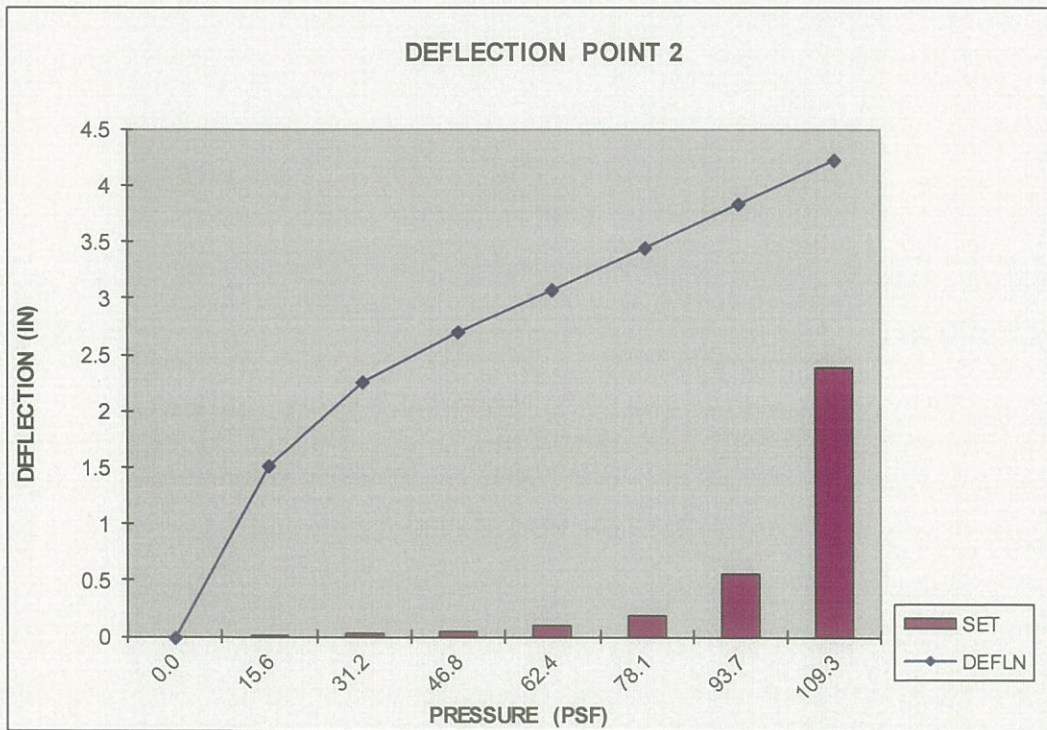
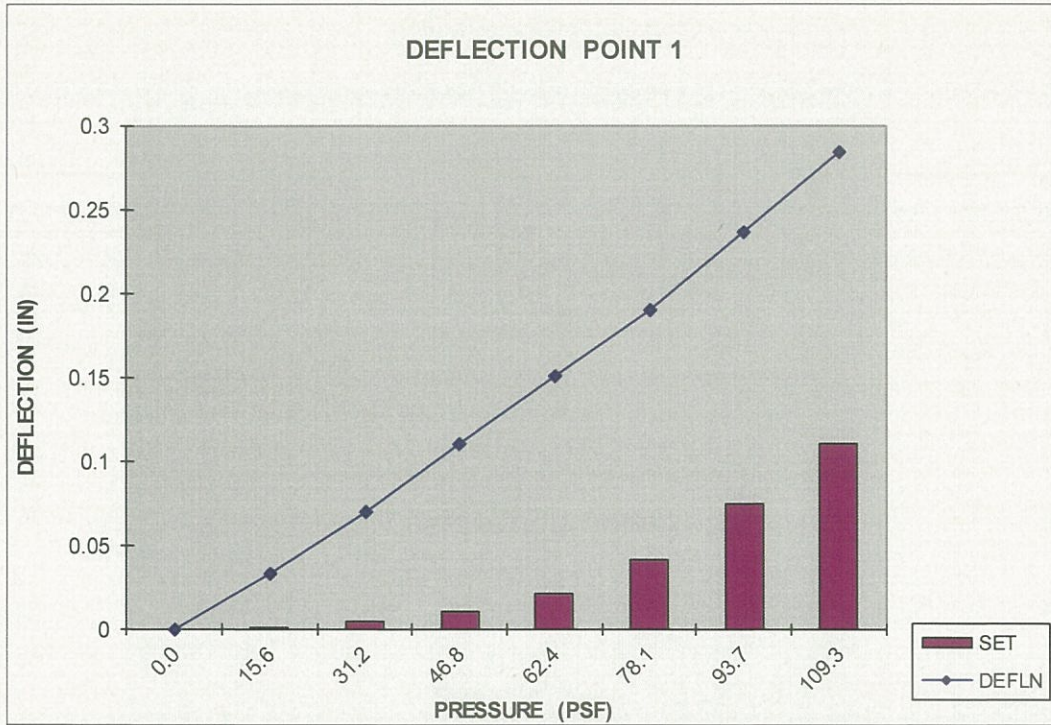

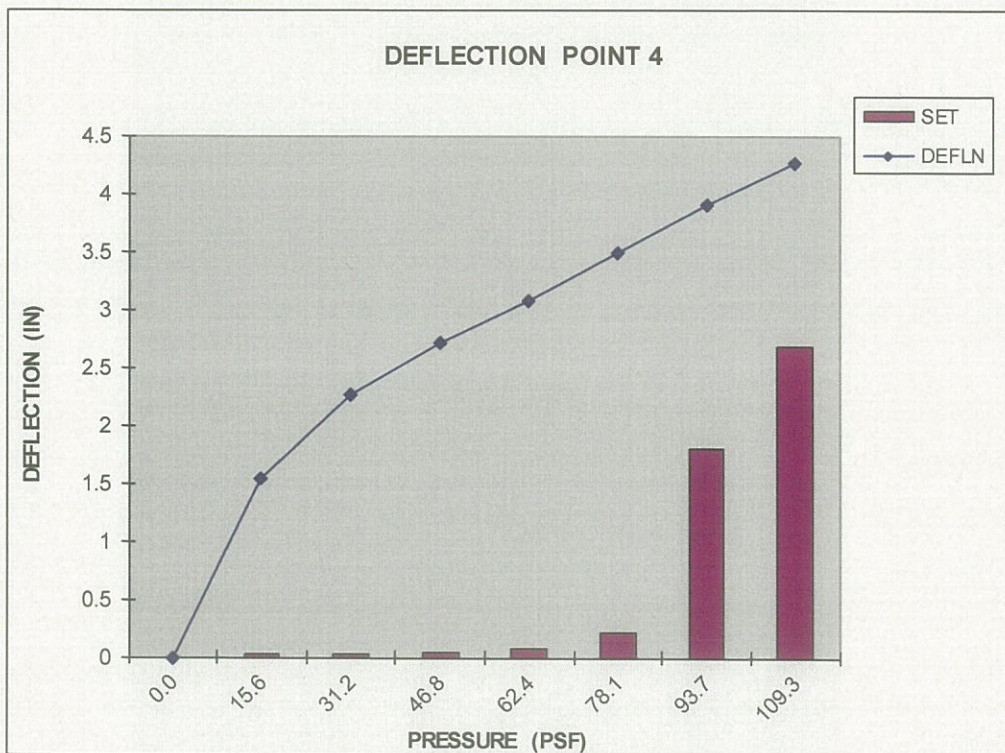
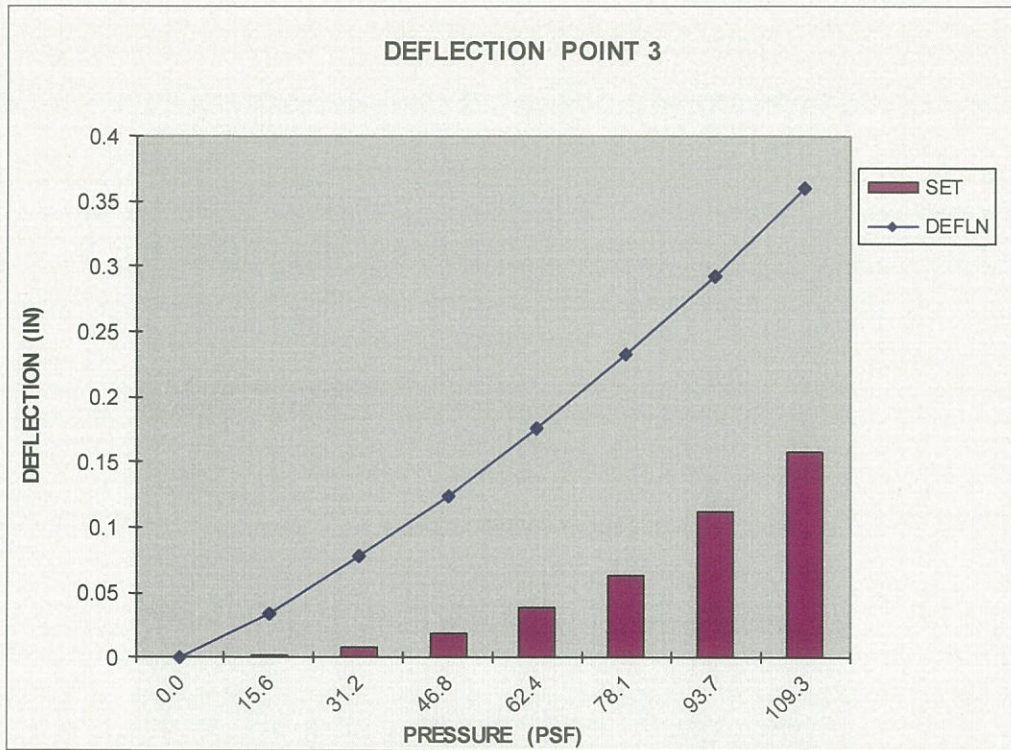

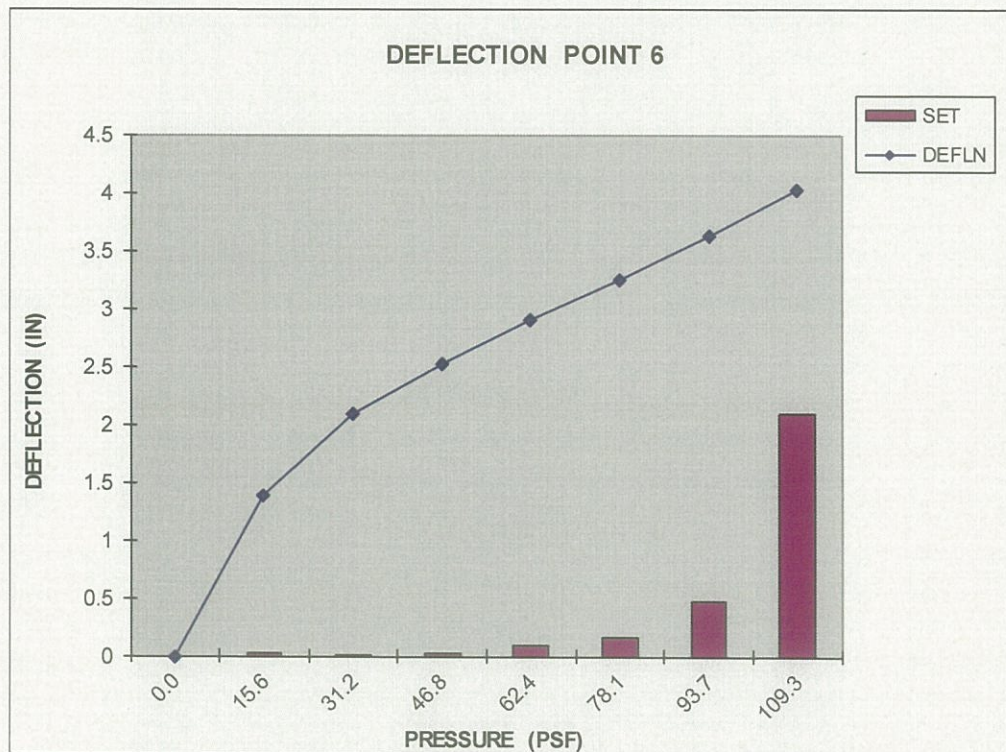
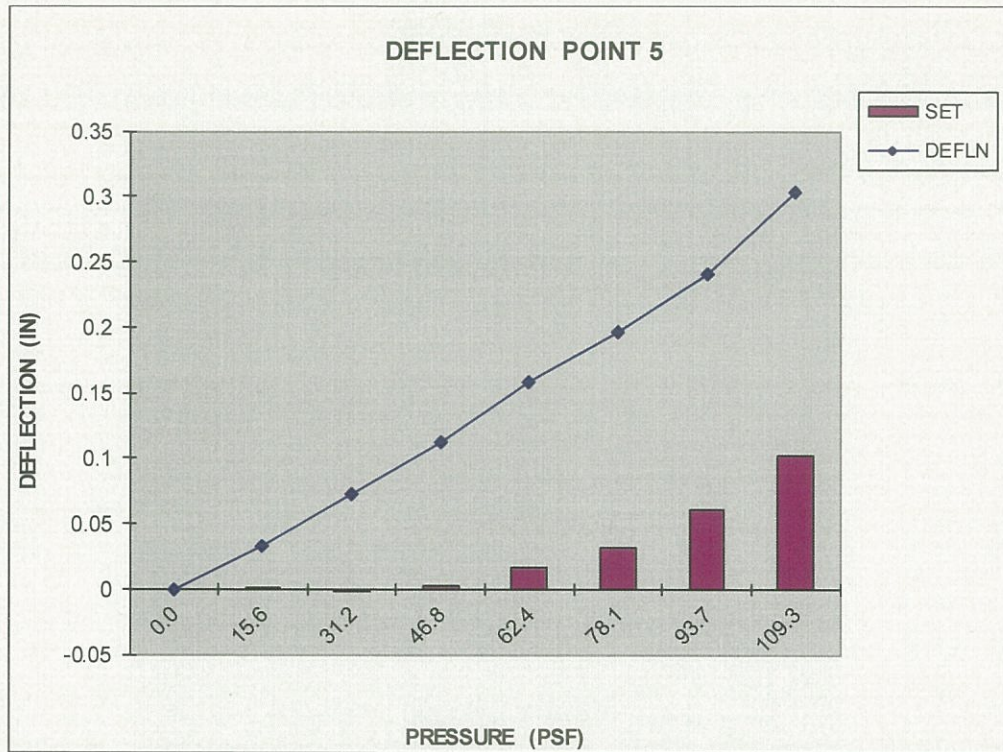

Project No. T149-19

## TEST #3

Specimen: T-PANEL - Metal Roof Panel, 16" wide x 0.032" aluminum with intermittent Clip

Clip Spacing: 2 ft o/c

### NEGATIVE (UPLIFT) PRESSURE

PETERSEN ALUM. T-PANEL 16" WIDE X 0.032" ALUM. (12 SPANS @ 2' O.C.) INTERMITTENT CLIP

LOAD (PSF)	DEFLECTION DIAL READINGS (INCHES)					
	D-1	D-2	D-3	D-4	D-5	D-6
0.0	0.000	0.000	0.000	0.000	0.000	0.000
15.6	0.033	1.622	0.036	1.588	0.031	1.665
0.0	0.008	0.067	0.007	0.070	0.006	0.074
31.2	0.089	2.513	0.081	2.437	0.068	2.563
0.0	0.017	0.097	0.013	0.090	0.013	0.105
46.8	0.154	3.155	0.137	3.017	0.109	3.201
0.0	0.032	0.140	0.023	0.118	0.017	0.150
62.4	0.227	3.760	0.208	3.629	0.162	3.803
0.0	0.052	0.258	0.036	0.162	0.029	0.321
78.1	0.275	4.113	0.260	4.001	0.198	4.138
0.0	0.066	0.386	0.053	0.463	0.039	0.444
93.7	0.328	4.563	0.330	4.439	0.252	4.566
0.0	0.078	0.460	0.071	0.453	0.048	0.478
109.3	0.335	4.595	0.404	4.872	0.314	4.987
0.0	0.115	0.554	0.085	0.494	0.066	0.583

### RESULTS:

Load held for 1 minute = 130 psf

Maximum Test Load = 132.1 psf (Panel disengaged from clip – Clip straightened out)

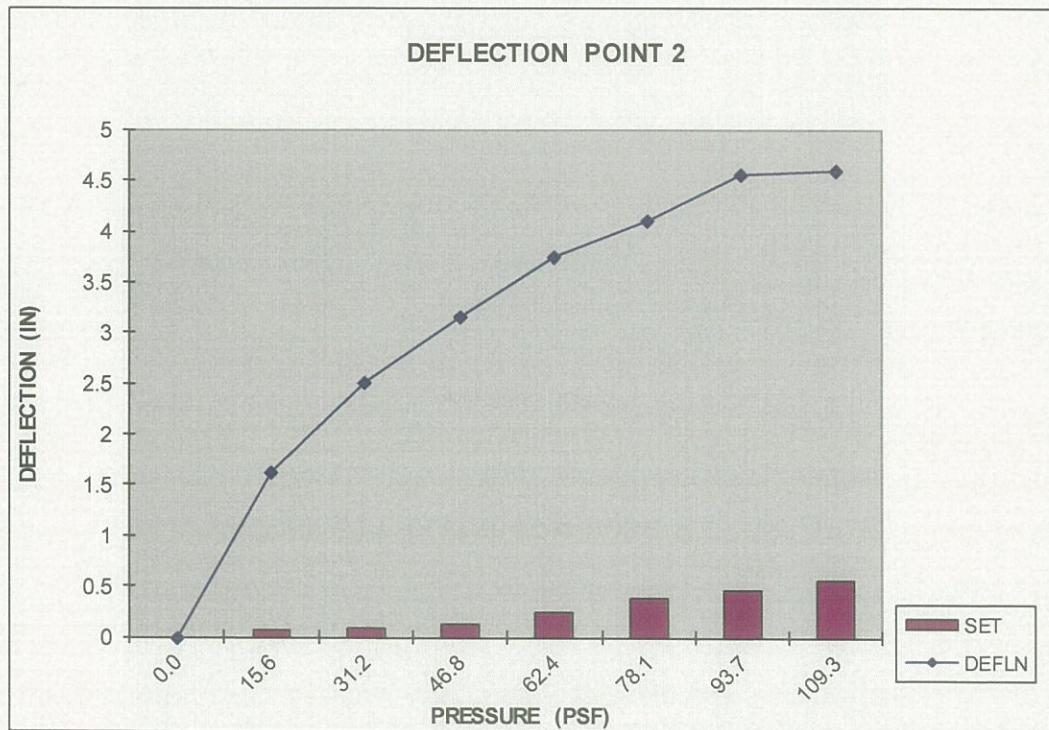
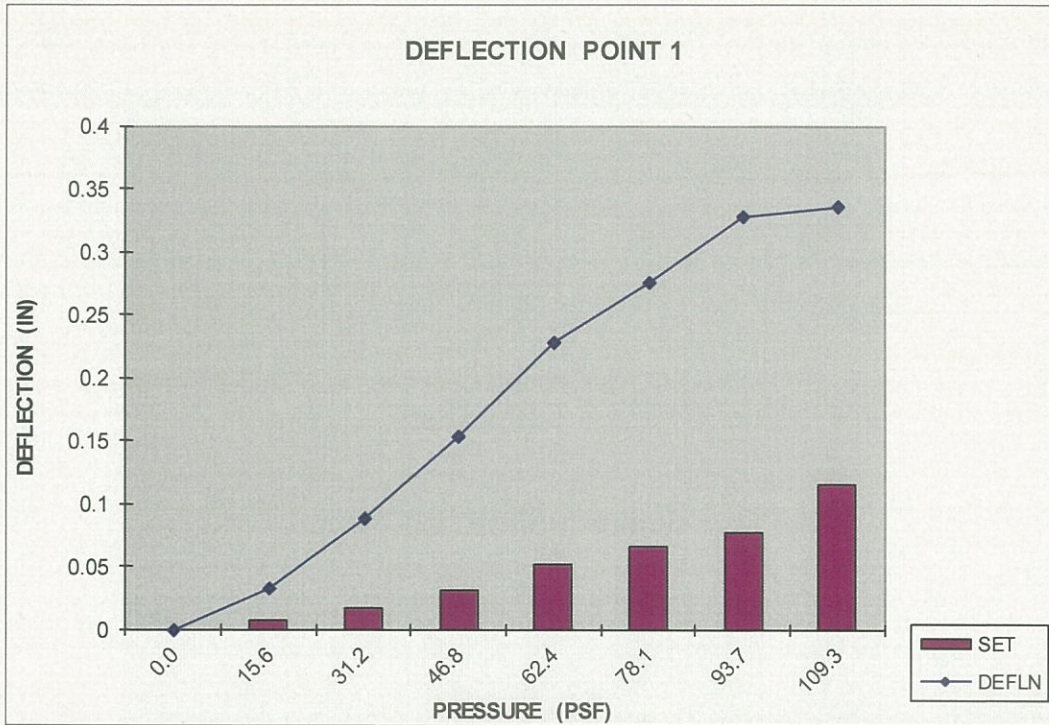

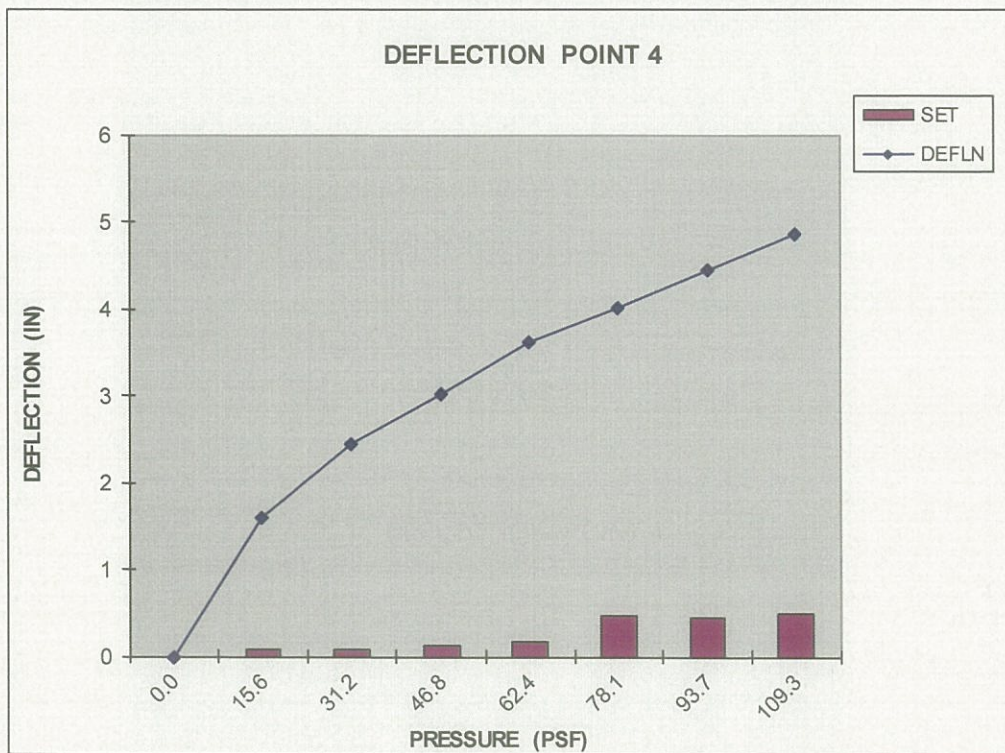
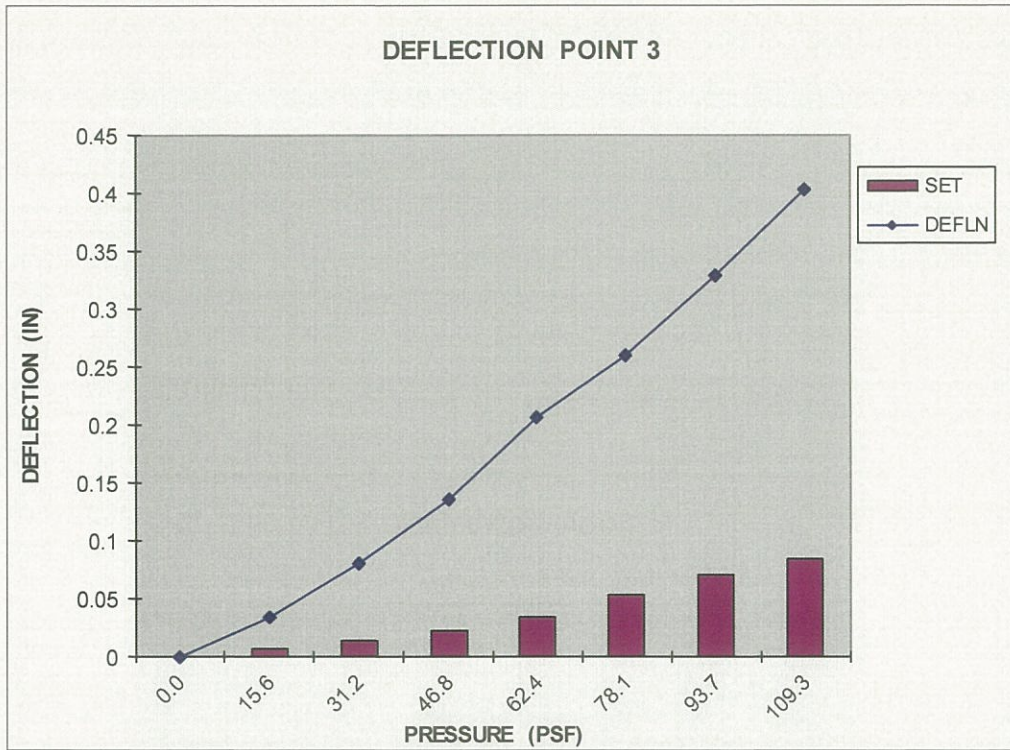

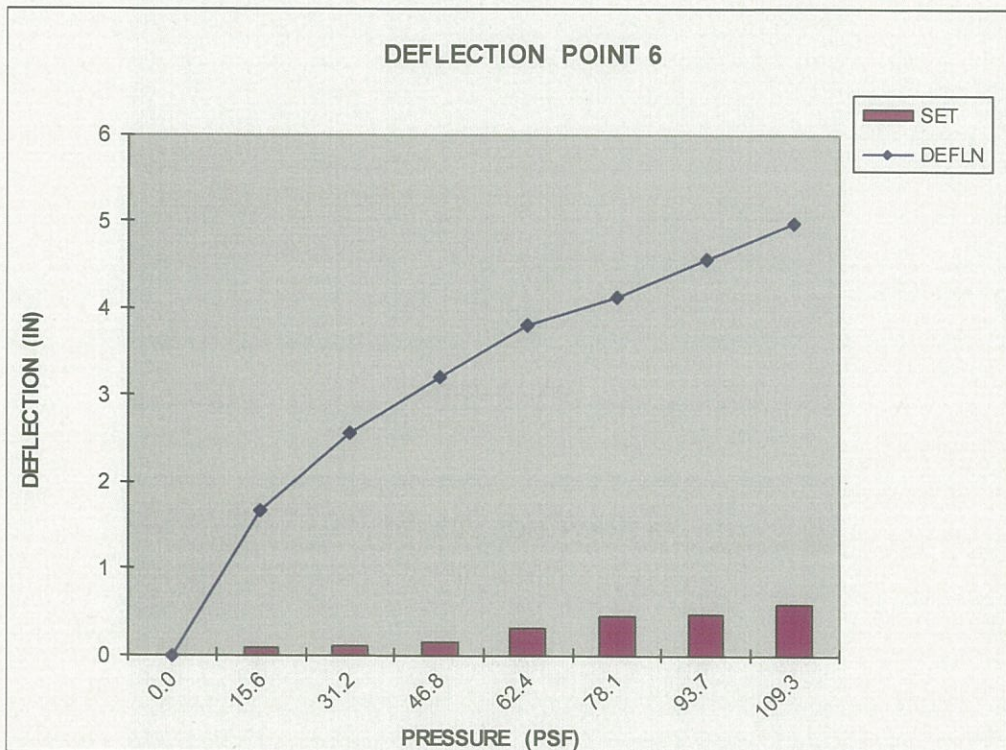
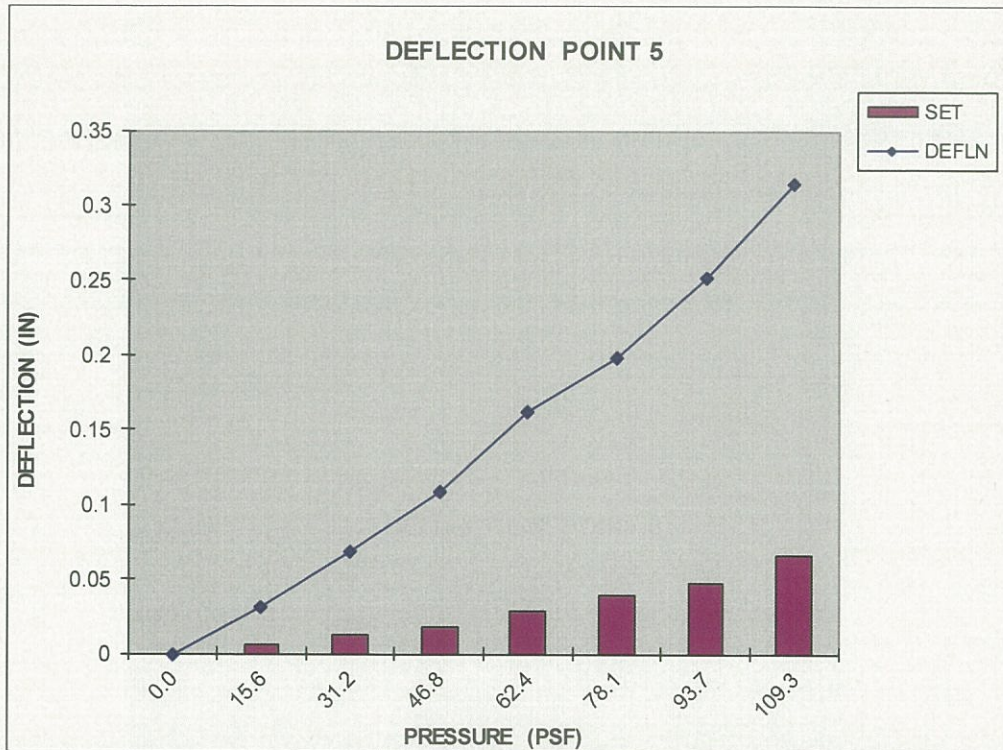

Project No. T149-19

## TEST #4

Specimen: T-PANEL - Metal Roof Panel, 16" wide x 0.032" aluminum with continuous Clip

Clip Spacing: 2 ft o/c

### NEGATIVE (UPLIFT) PRESSURE

PETERSEN ALUM. T-PANEL 16" WIDE X 0.032" ALUMINUM (12 SPANS @ 2' O.C.) CONT. CLIP

LOAD (PSF)	DEFLECTION DIAL READINGS (INCHES)					
	D-1	D-2	D-3	D-4	D-5	D-6
0.0	0.000	0.000	0.000	0.000	0.000	0.000
15.6	0.021	1.376	0.015	1.271	0.029	1.542
0.0	0.001	0.019	0.002	0.015	0.002	0.021
31.2	0.042	2.087	0.034	1.944	0.060	2.275
0.0	0.002	0.046	0.004	0.051	0.000	0.050
46.8	0.068	2.553	0.055	2.417	0.095	2.752
0.0	0.004	0.092	0.004	0.102	0.002	0.108
62.4	0.090	2.888	0.077	2.786	0.124	3.092
0.0	0.004	0.081	0.005	0.137	0.002	0.097
78.1	0.115	3.244	0.104	3.202	0.155	3.454
0.0	-0.002	0.136	0.004	0.484	-0.003	0.188
93.7	0.140	3.631	0.127	3.694	0.187	3.848
0.0	-0.005	0.327	0.006	1.429	-0.002	0.453
109.3	0.165	3.982	0.152	4.102	0.225	4.206
0.0	0.019	1.742	0.019	2.329	0.025	1.938
124.9	0.189	4.318	0.176	4.487	0.263	4.540
0.0	0.034	2.575	0.031	3.029	0.045	2.787
140.5	0.200	4.405	0.192	4.856	0.303	4.861
0.0	0.045	3.210	0.041	3.696	0.059	3.434
156.1	0.241	5.056	0.229	5.207	0.346	5.277
0.0	0.054	3.933	0.051	4.221	0.070	4.158

### RESULTS:

Load held for 1 minute = 280.8 psf

Maximum Test Load = 286 psf (Panel tore around fastener at fixed end)



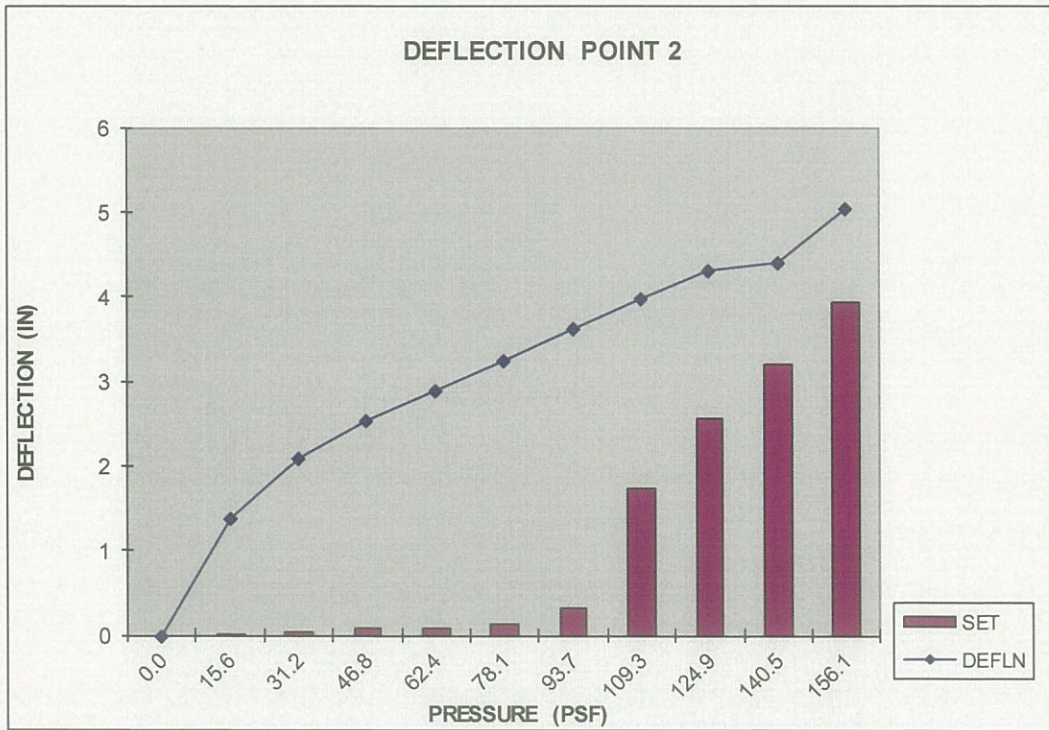
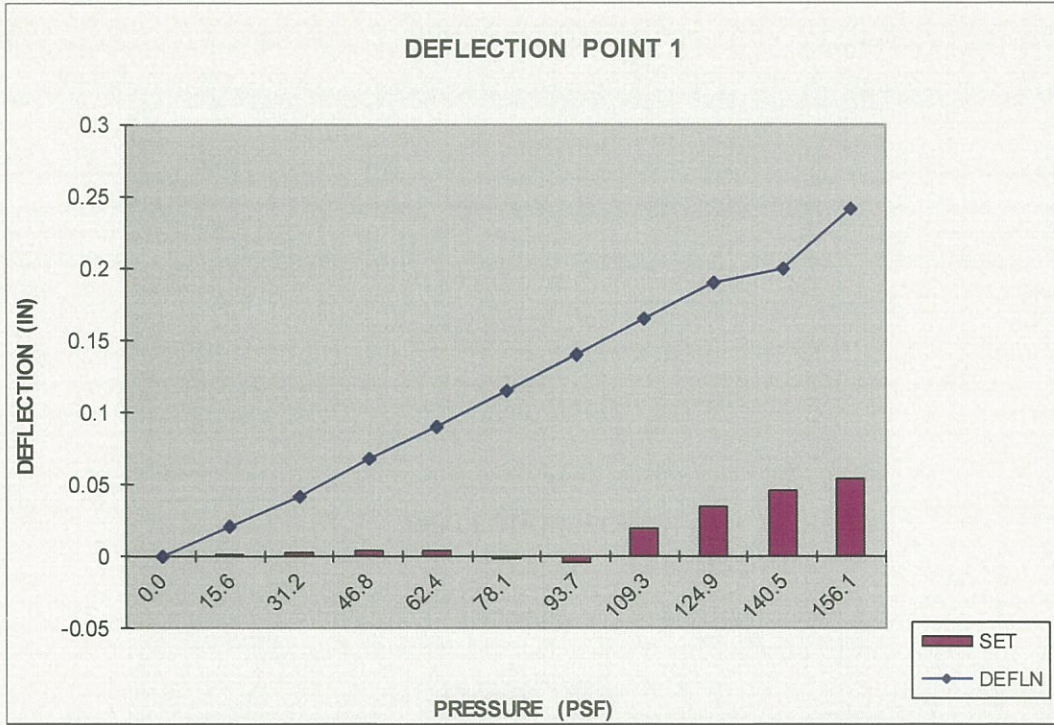

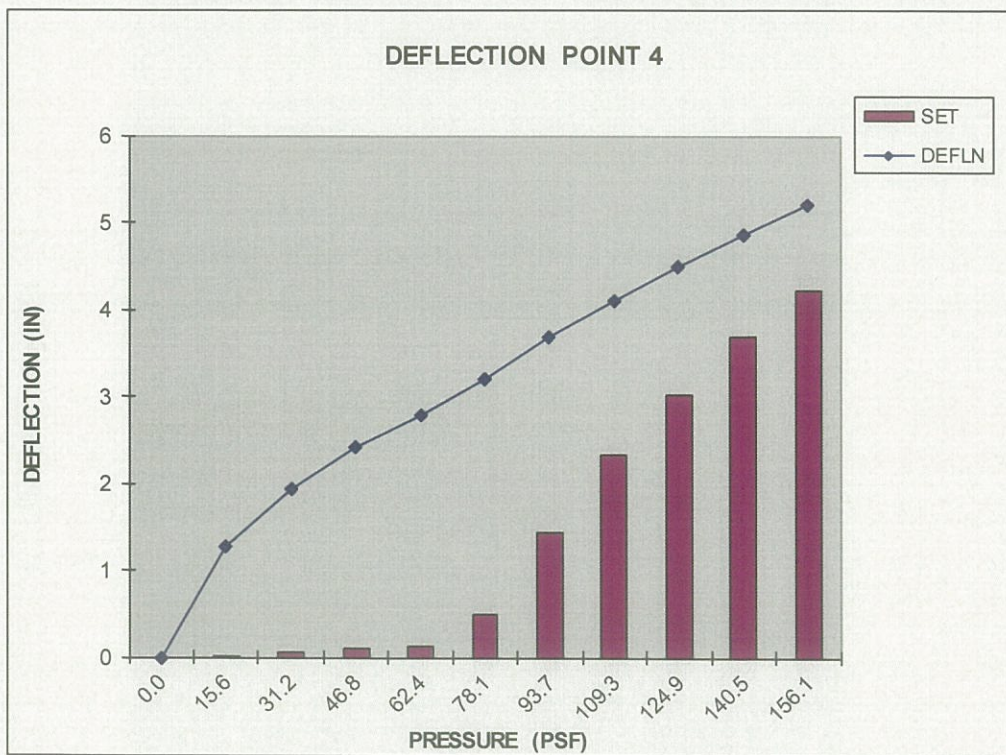
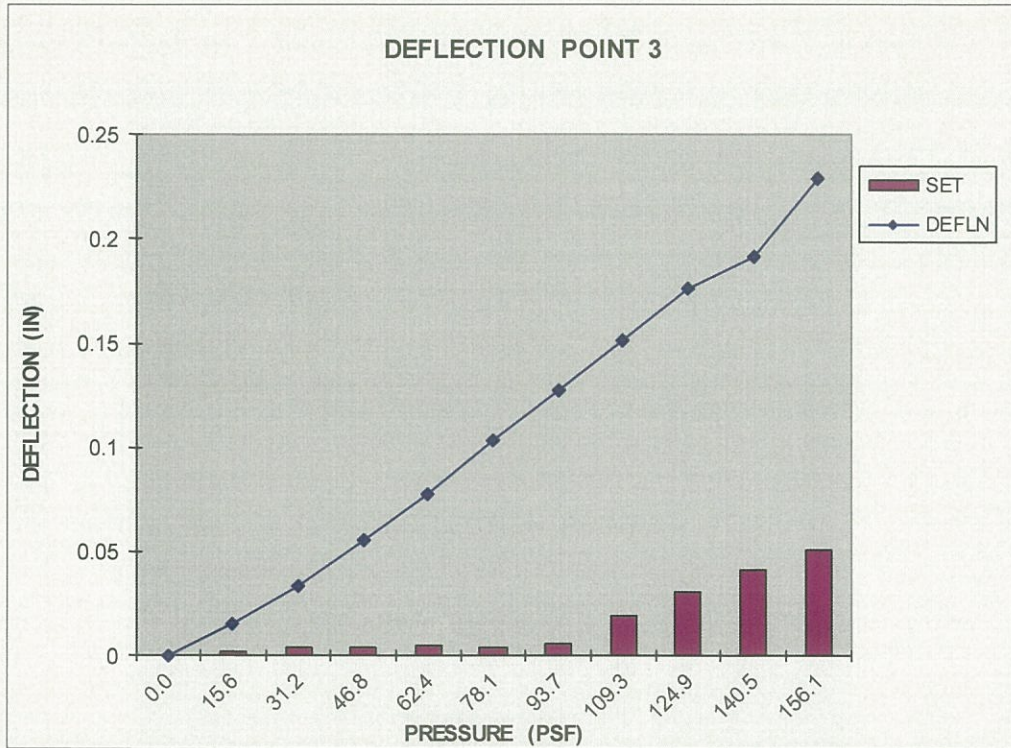

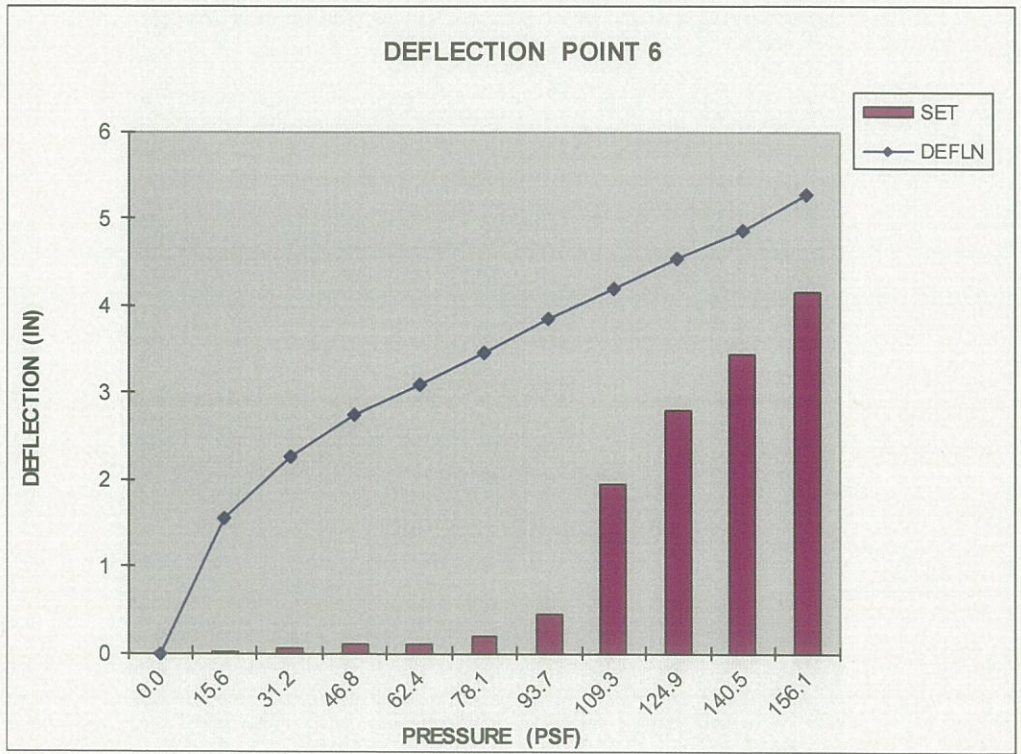
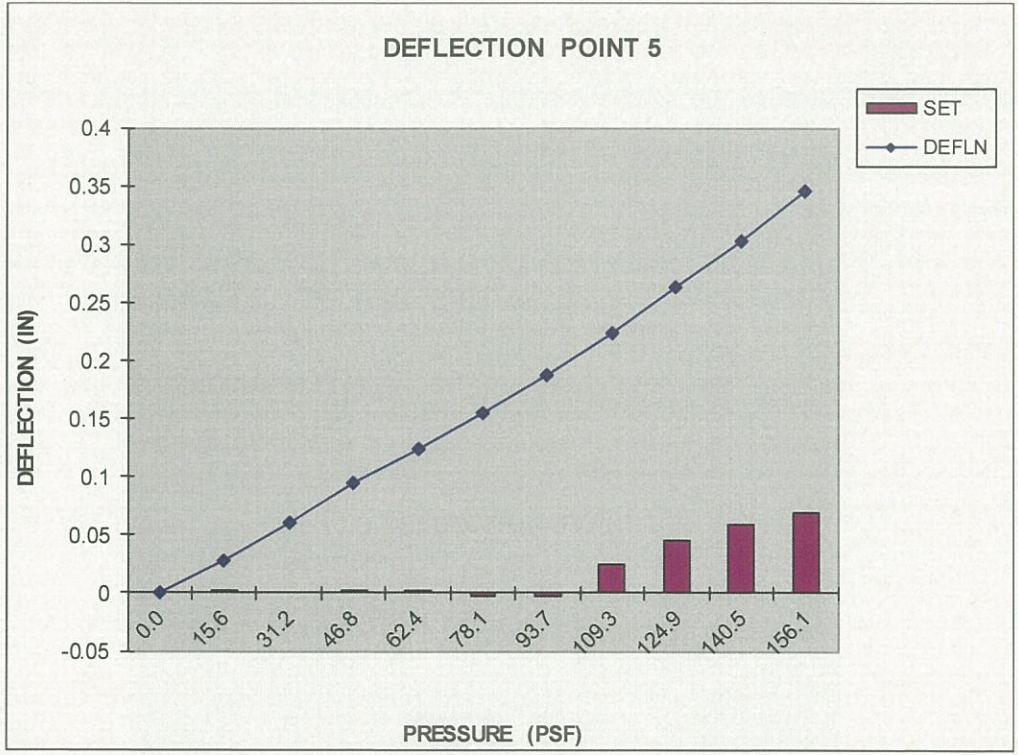

# TEST #1 & #2

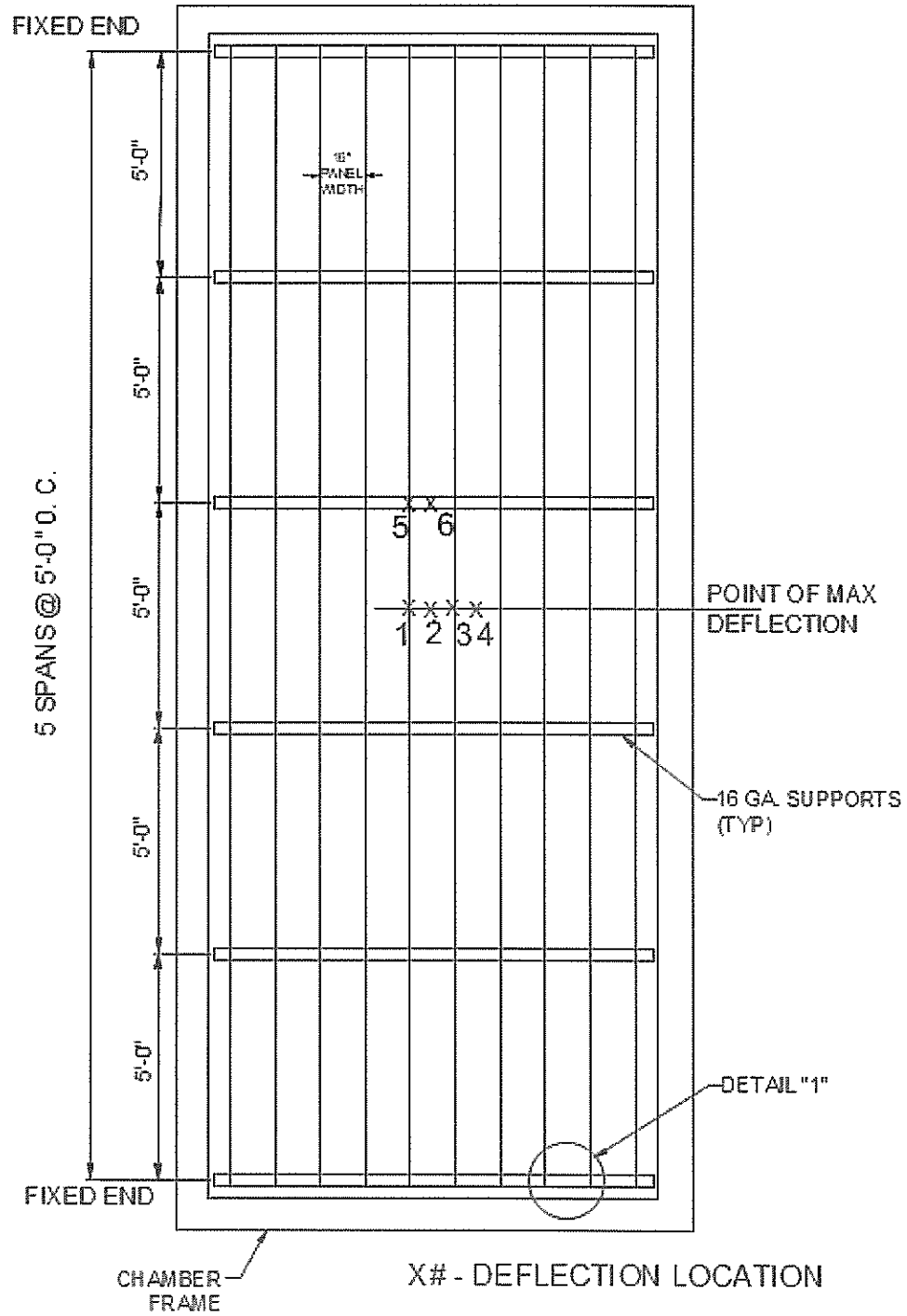

## PLAN VIEW

# TEST #3 & #4

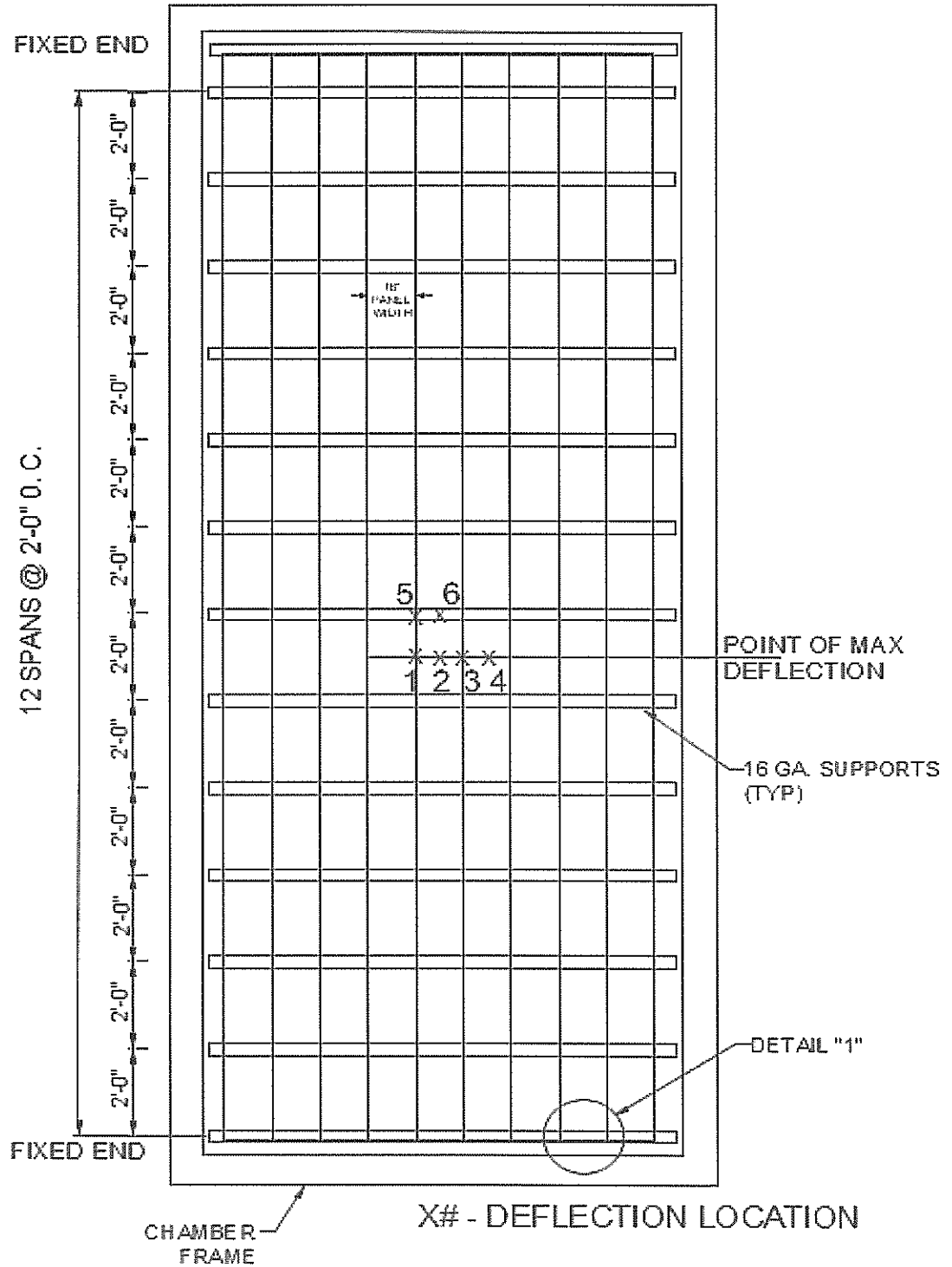

# PLAN VIEW

1/4-14 SELF DRILLING FASTENERS  
(5 PER PANEL AT FIXED ENDS)

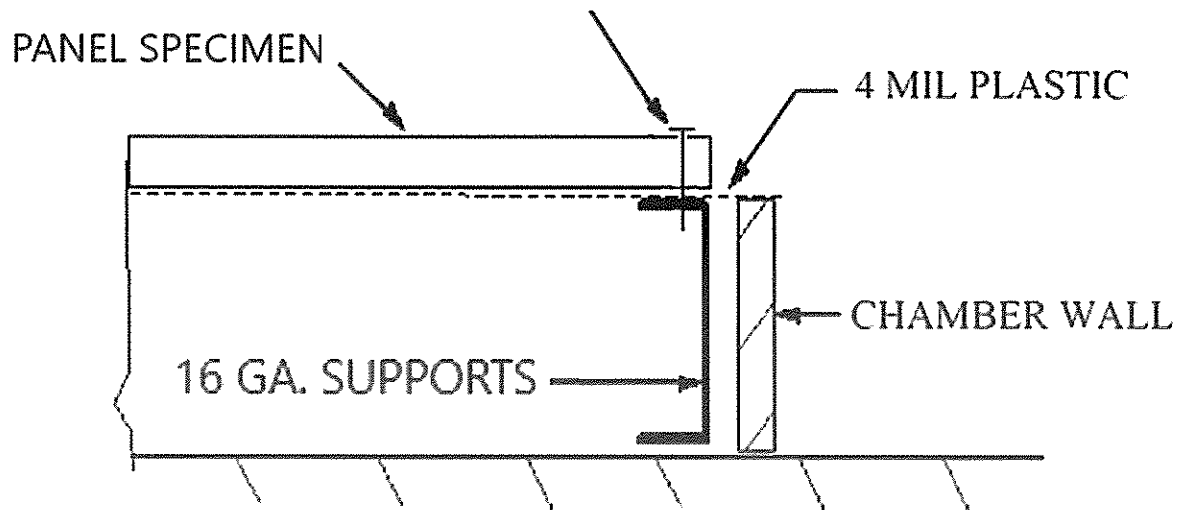

# DETAIL 1

Project No. T149-19

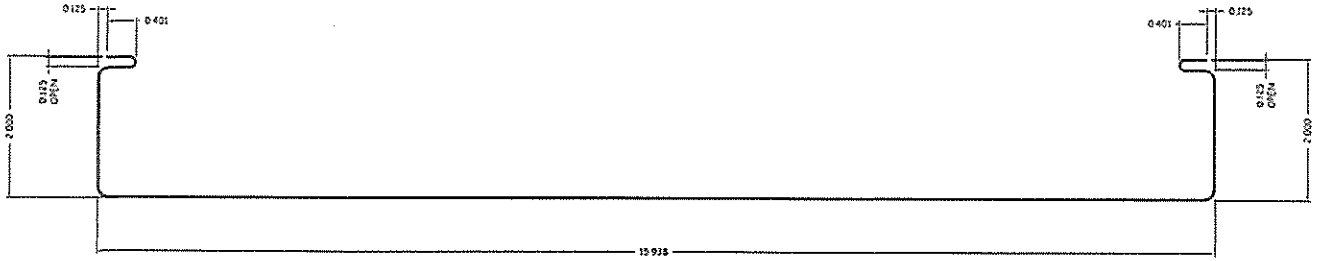

16" T PANEL

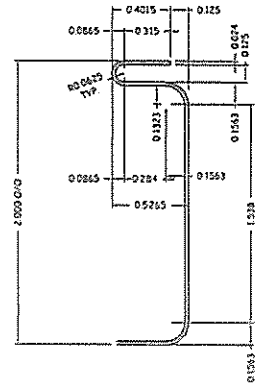
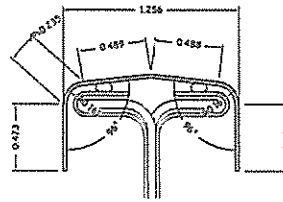
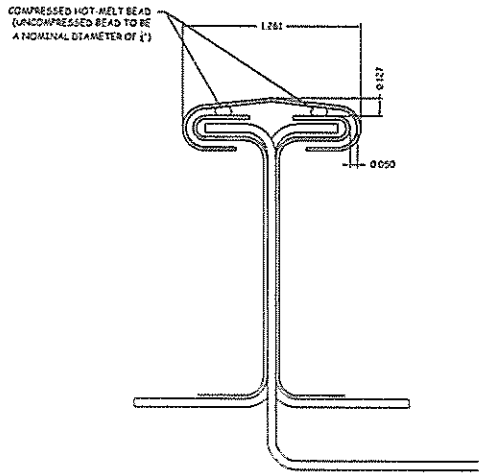

ENLARGED SIDE JOINT DETAIL

STUDY AT SIDE JOINT W/ CLIP CAP (AFTER SEAMING)

## PANEL PROFILE

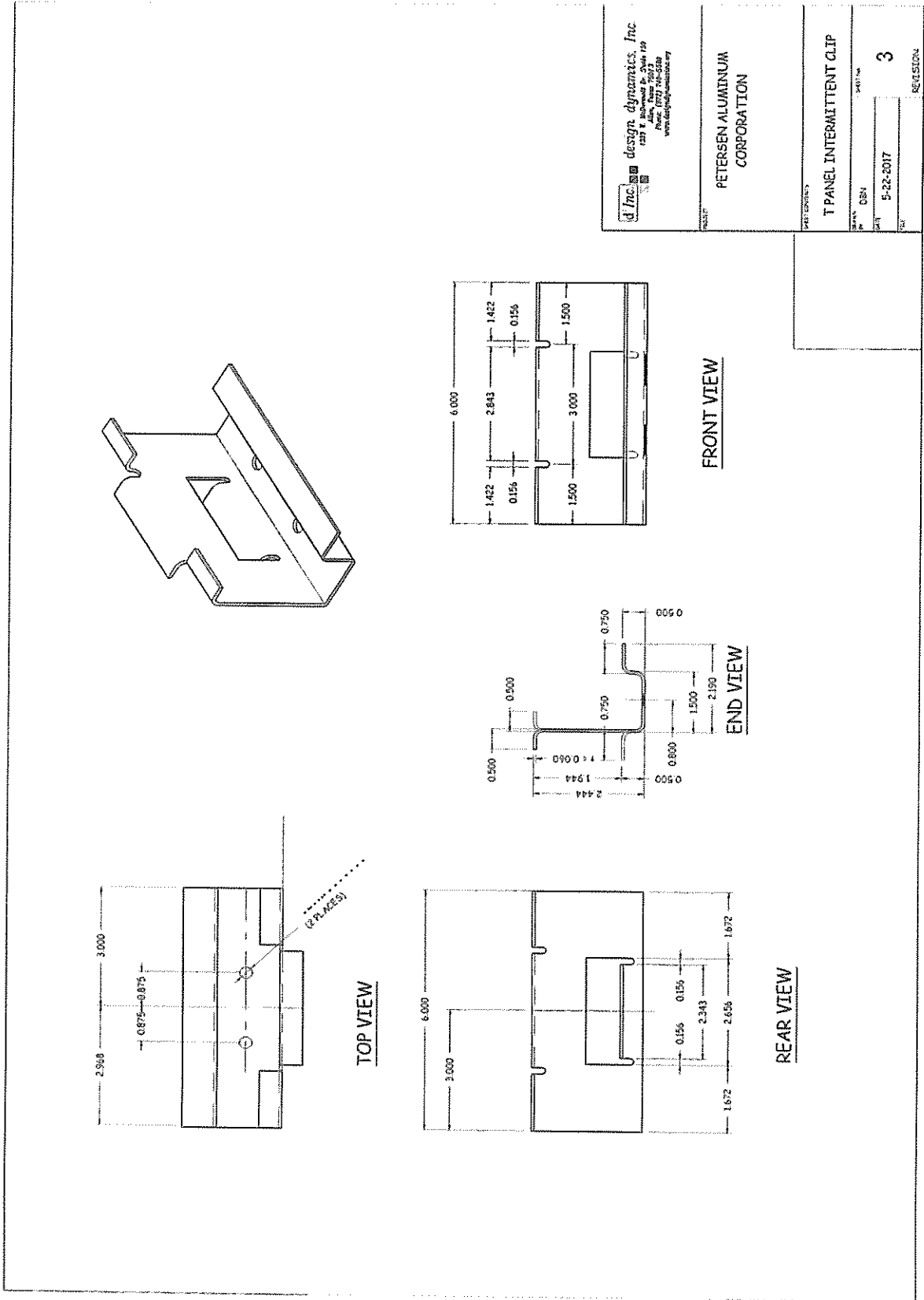

**d inc.** design dynamics, inc.  
 12214 Lee Road, Suite 119  
 Atlanta, Georgia 30338  
 Phone: (770) 740-0300  
 www.dynamicsmfg.com

PETERSEN ALUMINUM CORPORATION

T PANEL INTERMITTENT CLIP

DATE: 5-22-2017

REV: 3

REVISION:



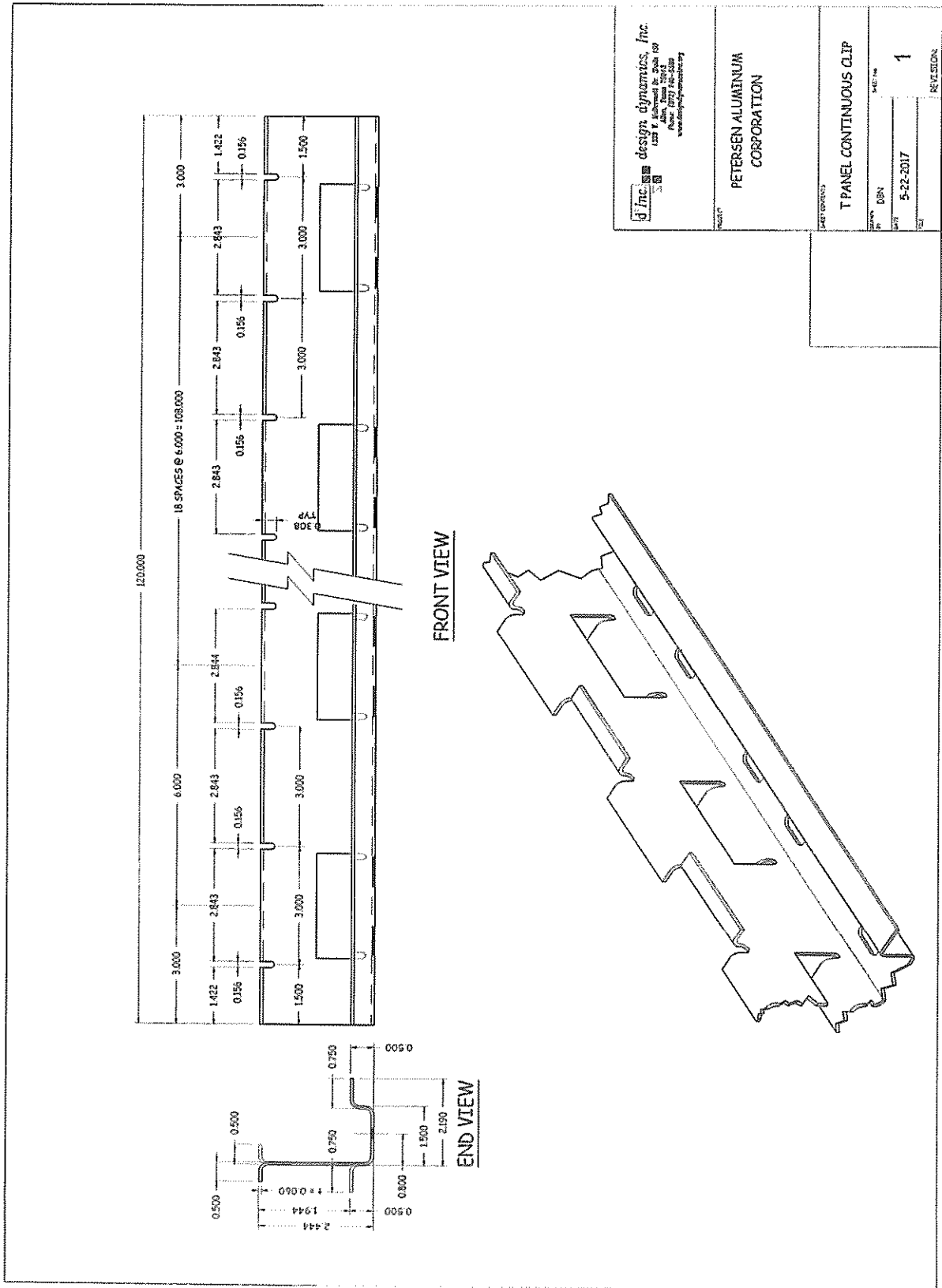

d inc. design dynamics, Inc.  
1222 W. Schmale Rd. Suite 100  
Aliso Viejo, CA 92656  
www.designdynamics.com

PETERSEN ALUMINUM CORPORATION

T PANEL CONTINUOUS CLIP

DATE: 5-22-2017  
REV: 1

REVISION

Project No. T149-19

## TENSILE TEST REPORT

Client: Petersen Aluminum  
10551 PAC Rd.  
Tyler, TX. 75707

Test Date: March 13, 2019

Test Method: ASTM B557-10

Material Description: T-PANEL - Metal Roof Panel, 16" wide x 0.032" aluminum

Sample No.	Width (in)	Thickness (in)	Yield Load (lb)	Max. Load (lb)	0.2% Offset Yield Strength (psi)	Tensile Strength (psi)	Elongation (% in 2 inches)
19011	0.506	0.030	388.7	427.6	25,605	28,116	9.17

Equipment Used: Tensile Machine #QT7-061196-020  
Caliper #1074379  
Extensometer #10311744D  
Micrometer #110596927