

PAC-TITE QUICKLOCK RADIUS COPING

- Premanufactured radius coping utilizing a non-penetrating lock system. The non-penetrating quicklock joint is then factory sealed watertight.
- 2 to 3 week lead time instead of the standard 5 to 6 week lead time for welded post coated radius coping.
- No welding required.

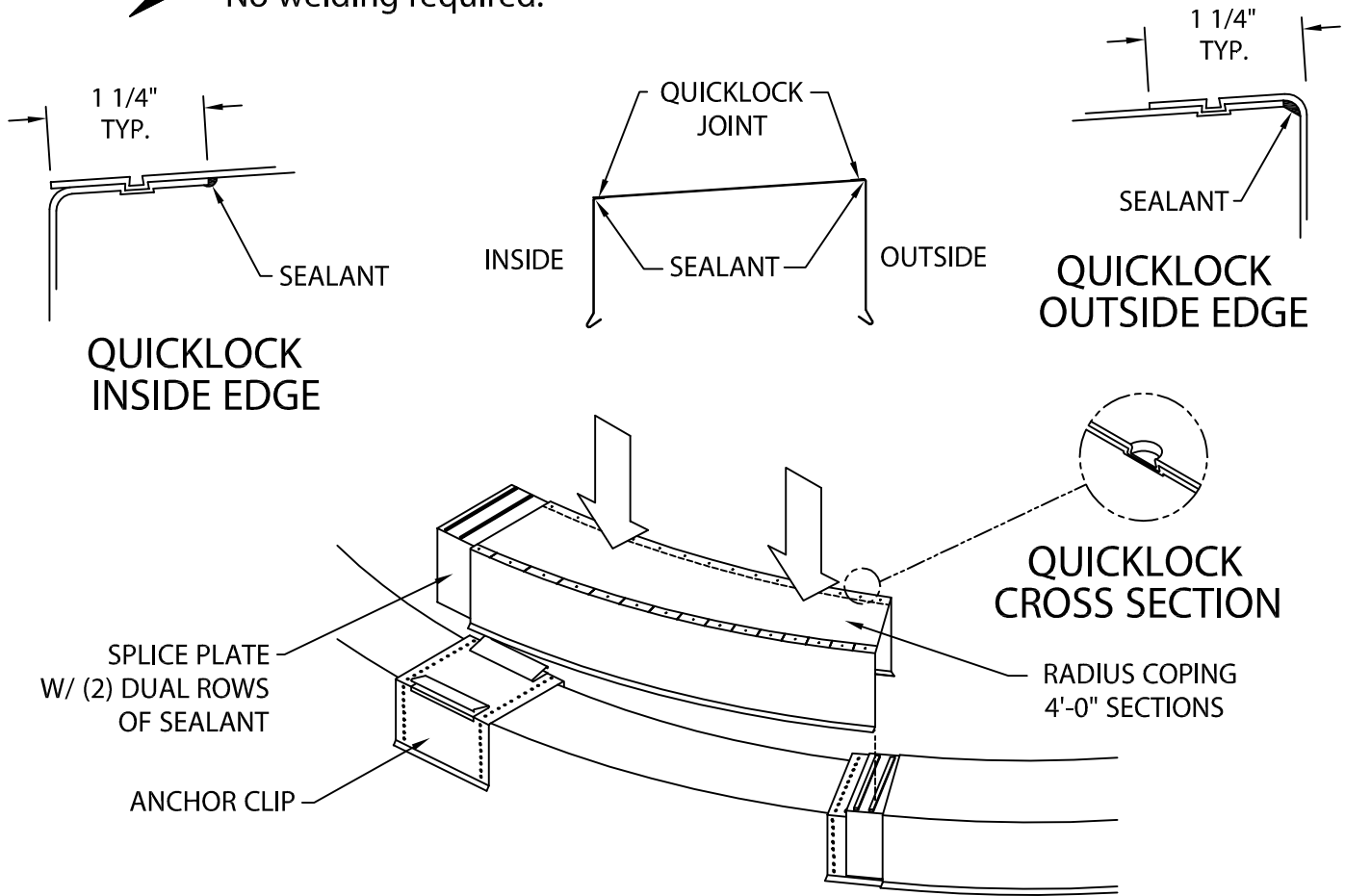

- Full snap-on design allows for fast easy installation. No crimping required.
- Competitively priced when compared to locally fabricated roofer shop designs.
- Custom fabricated to fit exact job requirements
- Corrosion resistant, stainless steel springs provided factory attached to anchor clips.
- Concealed splice plates with sealant strips factory applied. No unsightly cover plates.