

# PAC-LOC FASCIA 2000

FULLY ADHERED OR MECHANICALLY ATTACHED SINGLE-PLY VERSION

**IMPORTANT!** MUST INDICATE PROPER RADIUS CONDITION BY CIRCLING APPROPRIATE OUTSIDE FACE

PROVIDING A RADIUS  
THE RADIUS MAY BE PROVIDED IN ONE OF TWO METHODS:

1.) THE ACTUAL KNOWN RADIUS IS

(SMALLEST RADIUS ALLOWED IS 12'-0" [3.65 m])

OR

2.) FIELD CONDITION MEASUREMENTS

NOTE: REFER TO ATTACHED WORKSHEET FOR FURTHER INFORMATION

(MAX. RISE ALLOWED IS 1 1/8" [29 mm] ON 36" CHORD)

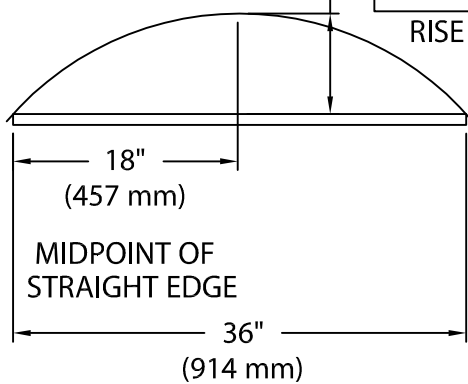

LENGTH OF STRAIGHT EDGE

NOTE: CHECK MEASUREMENTS ALONG ENTIRE RADIUS.

DETAIL A

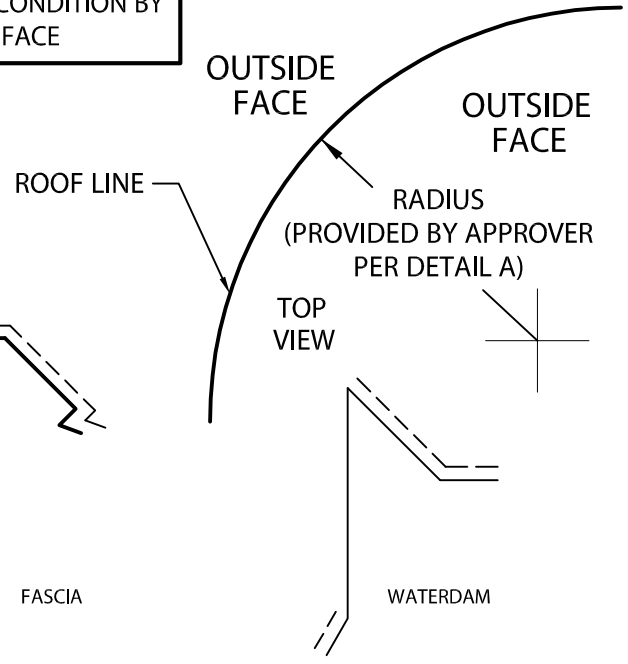

--- INDICATES AREAS THAT WILL BE SLIT AS NEEDED TO ACCOMMODATE RADIUS

## PAC-LOC FASCIA 2000 DIMENSIONS

PRODUCT ID. NO.	H DIM	X DIM	NAILER COVERAGE
<input type="checkbox"/> FA-50	5 1/4" (133 mm)	2 7/8" (73 mm)	1 NAILER
<input type="checkbox"/> FA-65	6 3/4" (171 mm)	4 3/8" (111 mm)	2 NAILERS
<input type="checkbox"/> FA-80	8 1/4" (210 mm)	5 7/8" (149 mm)	3 NAILERS
<input type="checkbox"/> FA-95	9 3/4" (248 mm)	7 3/8" (187 mm)	4 NAILERS
<input type="checkbox"/> FA-110	11 1/4" (286 mm)	8 7/8" (225 mm)	5 NAILERS
<input type="checkbox"/> FA-125	12 3/4" (324 mm)	10 3/8" (264 mm)	6 NAILERS

Fabrication will proceed only after receipt of signed print approval.

## Print Approval:

Architect and/or contractor shall verify all dimensions, sizes and quantities. All products to be installed in strict accordance with Petersen Aluminum's printed instructions.

Approved by: \_\_\_\_\_

Date: \_\_\_\_\_

## MATERIAL:

\*Oil canning can occur on larger face heights. Recommend .050" (1.27 mm) or .063" (1.60 mm) for face heights above 8 1/4" (210 mm)

\_\_\_\_\_ 24 Ga. (.65 mm) Galv. Steel\*  
 \_\_\_\_\_ .040" (1.01 mm) Alum.\*  
 \_\_\_\_\_ .050" (1.27 mm) Alum.  
 \_\_\_\_\_ .063" (1.60 mm) Alum.  
 \_\_\_\_\_ OTHER \_\_\_\_\_

Color: \_\_\_\_\_

Finish: \_\_\_\_\_

## QUANTITIES:

\_\_\_\_\_ Lineal Feet 12'-0" (3.65 m) Lengths

PROJECT:

ARCHITECT:

ROOFING CONTRACTOR:

REPRESENTATIVE/DISTRIBUTOR:



Phone: 800-323-1960 Fax: 800-722-7150

www.pac-clad.com

e-mail: info@pac-clad.com

DATE: 10/06/10

DRN BY: JJC

CKD BY: SAK

SHT.# \_\_\_\_ OF \_\_\_\_

DWG# 41010-12233

B