

PAC EXTENDED SNAP EDGE

FULLY ADHERED OR MECHANICALLY ATTACHED SINGLE-PLY VERSION

INSTALLATION INSTRUCTIONS

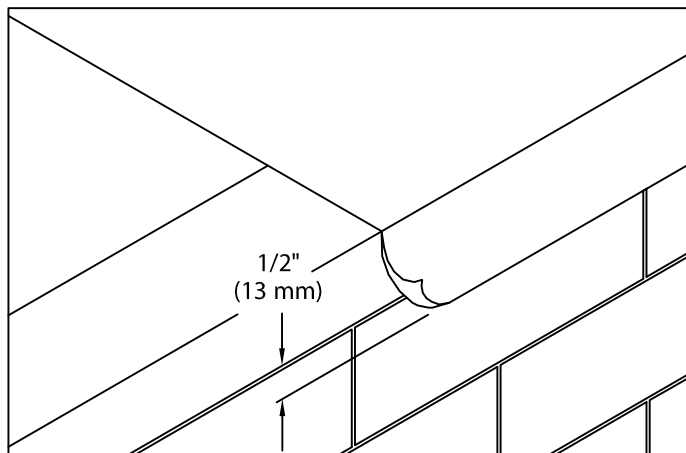

1. Roof Membrane

Position membrane over the roof edge and down outside face of wall, covering wood nailer(s) completely. Allow 1/2" (13 mm) excess membrane.

IMPORTANT! Outside edge of wood nailer(s) (minimum 2 x 4) shall be aligned flush with or extend slightly past outermost edge of wall.

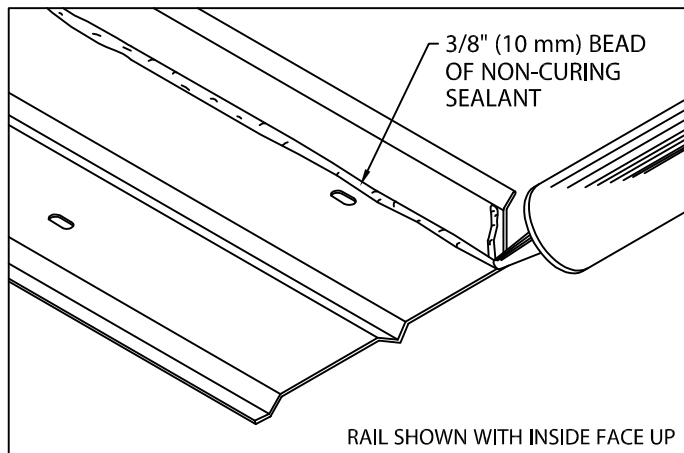

2. Miter & Scupper Base Rail (Preparation)

Lay miters and spillout scuppers on deck with outside face down. Be sure aluminum base rail is clean and free of dirt or dust. Apply a heavy 3/8" (10 mm) bead of non-curing sealant to the right angle intersection of the deck flange and back of base rail as shown. Application of sealant is required along the full length of each miter base rail. Apply a similar 3/8" (10 mm) bead of sealant to the flange's left end, as you look at the outside face of the rail section.

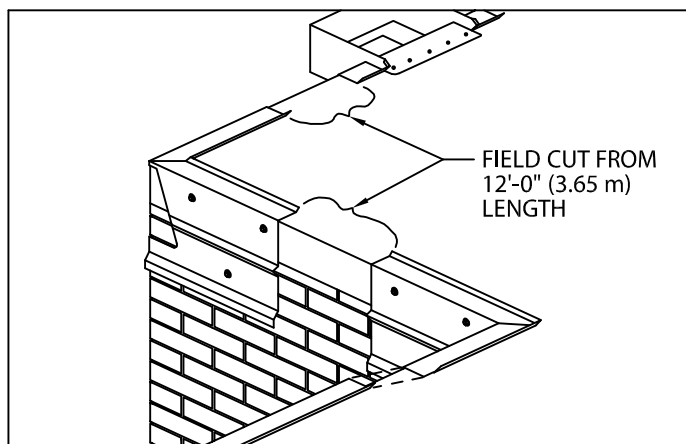

3. Base Rail Miter Installation

Fold roofing membrane at corners and install miters using 2" (51 mm) hex head stainless steel fasteners at top of formed rail and 1/4" (6 mm) x 1 1/4" (32 mm) masonry/wood fasteners at bottom of rail using driver bit provided by Petersen Aluminum. Next locate and install spillouts and scuppers with sealant and fasteners.

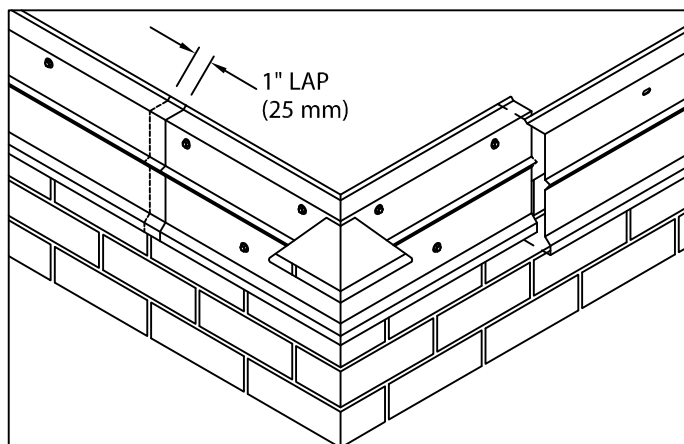

4. Base Rail Installation

Install 12'-0" (3.65 m) sections of base rail with sealant as shown in step 2. Install base rail from right to left, (as seen from roof top) lapping base rail joints 1" (25 mm). Fasten base rail 12" (305 mm) O.C. through the slots using the 2" (51 mm) stainless steel fasteners provided and 24" (610 mm) O.C. using 1/4" (6 mm) x 1 1/4" (32 mm) wood/masonry fasteners provided. Field cut sections as necessary.



Phone: 800-323-1960 Fax: 800-722-7150

www.pac-clad.com

e-mail: info@pac-clad.com

DATE: 08/09/10

DRN BY: JJC

CKD BY: SAK

SHT.# 1 OF 3

DWG# 41110-12261

A

PAC EXTENDED SNAP EDGE

FULLY ADHERED OR MECHANICALLY ATTACHED SINGLE-PLY VERSION

INSTALLATION INSTRUCTIONS

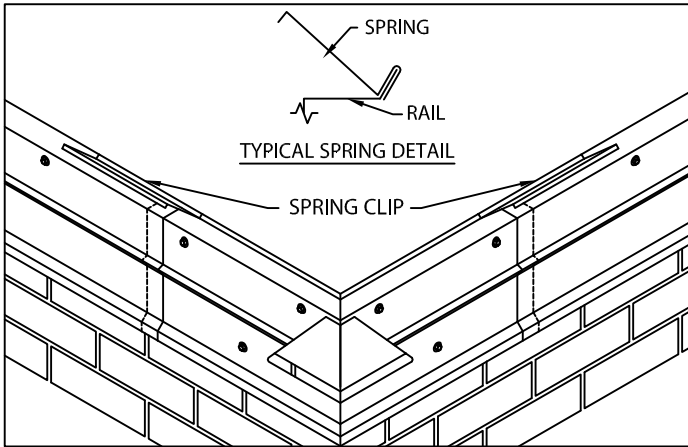

5. Spring Clips

Center (2) 6" (152 mm) wide stainless steel springs at each end of fascia miter cover.

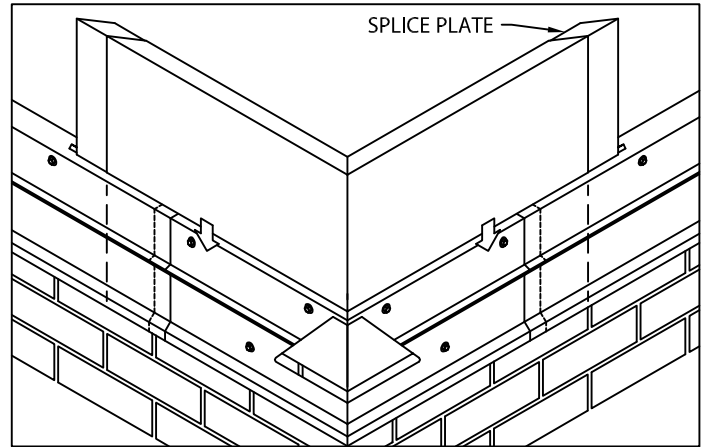

6. Fascia Miter Covers

Place splice plate into each end of miter cover. Simply position the cover atop rail and with palm of hand apply slight pressure downward until engaged to base rail.

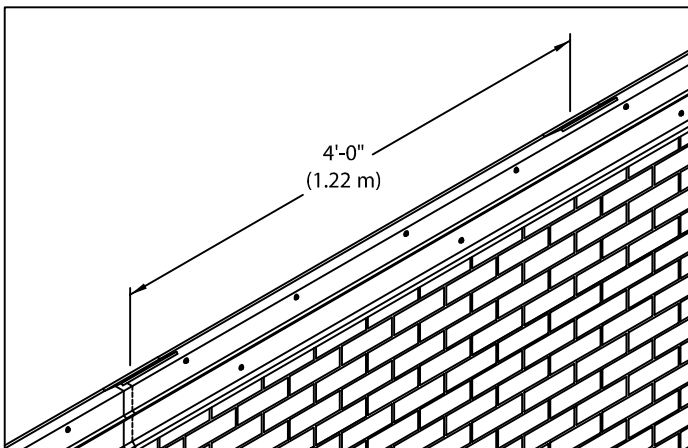

7. Spring Clips

Position 6" (152 mm) wide stainless steel spring clips starting at fascia cover end and every 4'-0" (1.22 m) on the installed base rail as shown.

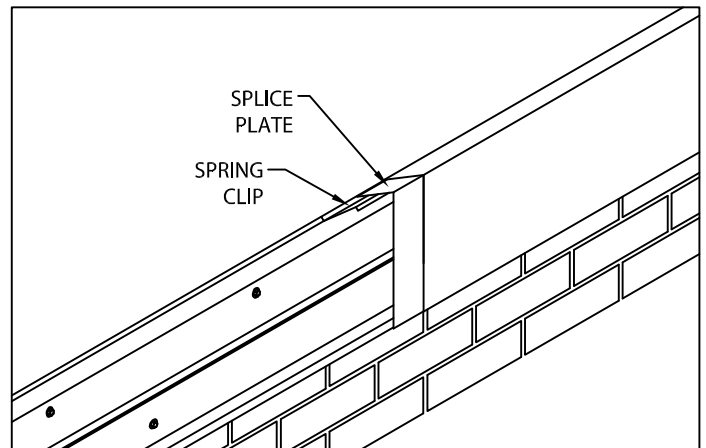

8. Fascia Covers

Position 12'-0" (3.65 m) fascia covers on top of base rail. Fascia covers shall be installed from left to right as seen from rooftop. Place splice plate in right end of cover. Snap right cover onto base rail by applying downward pressure with palm of the hand until the fascia cover is fully engaged along the entire length. Field cut covers as required using fine tooth hacksaw.

IMPORTANT! Be sure to remove protective plastic film prior to installing each fascia section.

PAC EXTENDED SNAP EDGE

FULLY ADHERED OR MECHANICALLY ATTACHED SINGLE-PLY VERSION

INSTALLATION INSTRUCTIONS

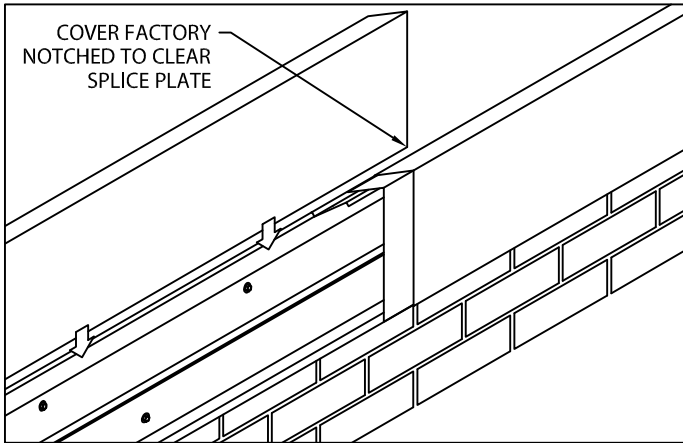

9. Fascia Covers

Position pre-notched cover and snap onto base rail by pressing down with the palm of your hand until the cover is fully engaged along the entire length. Allow 3/8" (10 mm) gap between cover sections. Field cut where necessary using the fine tooth hacksaw.

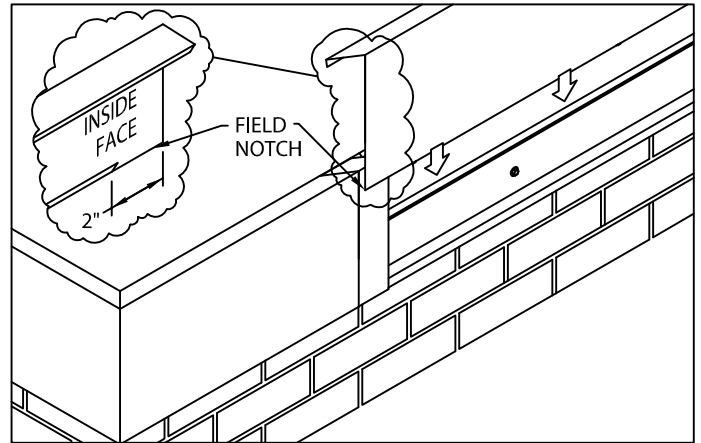

10. Fascia Covers at Miter

Field notch right side of cover as shown. Snap onto base rail by pressing down with the palm of your hand until the cover is fully engaged along the entire length. Allow 3/8" (10 mm) gap between cover sections. Field cut where necessary using the fine tooth hacksaw.

TYPICAL INSTALLATION

