

# PAC-TITE GOLD COPING ENDCAPS

WELDED POST-FINISHED ENDCAP ASSEMBLY

STANDARD ENDCAP LENGTH IS 18"

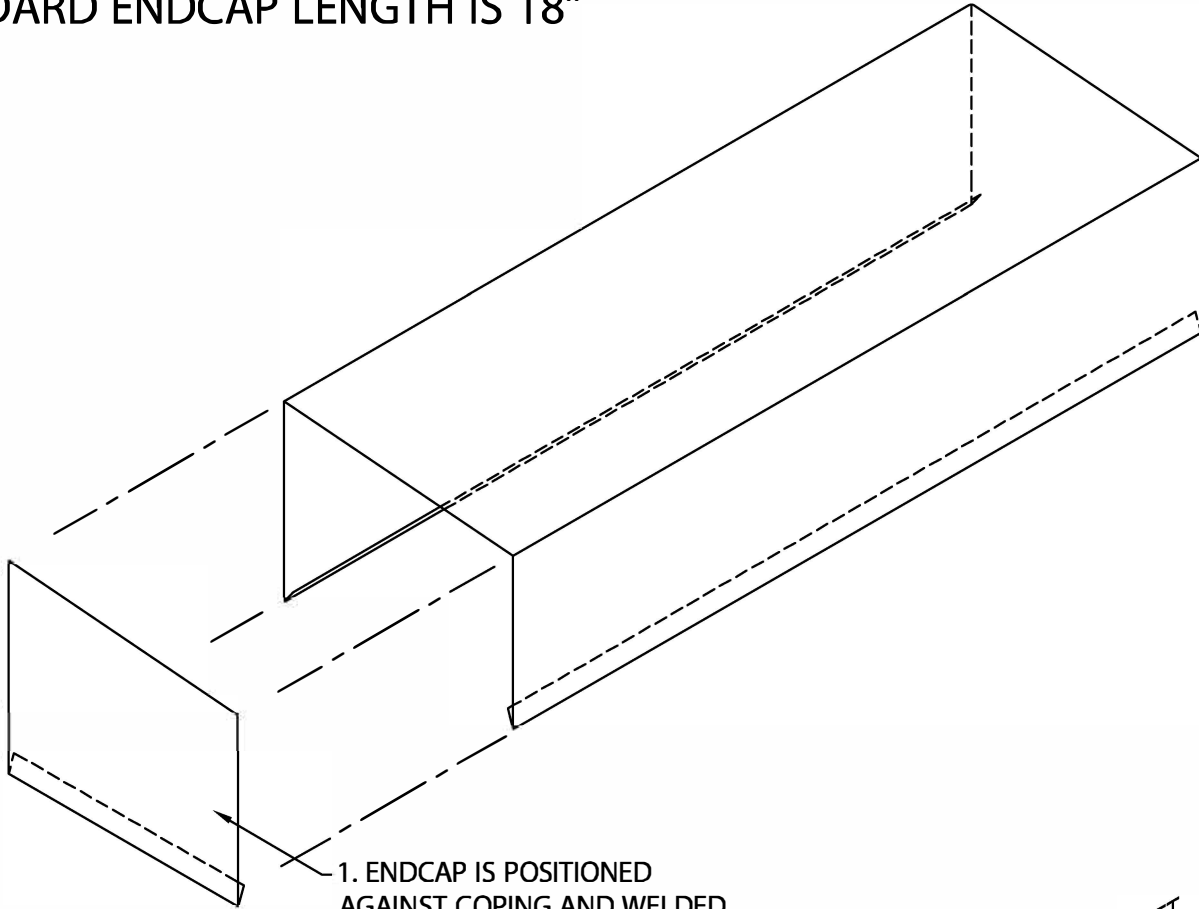

2. PIECE IS POST-COATED AFTER FABRICATION AND WELDING

OUTSIDE FACE

LEFT ENDCAP

INSIDE FACE

WELDED ENDCAPS ARE FABRICATED WITH FULLY WELDED OUTSIDE CORNERS