

PAC-TITE COPING ENDCAPS

QUICKLOCK ENDCAP ASSEMBLY

STANDARD ENDCAP LENGTH IS 18"

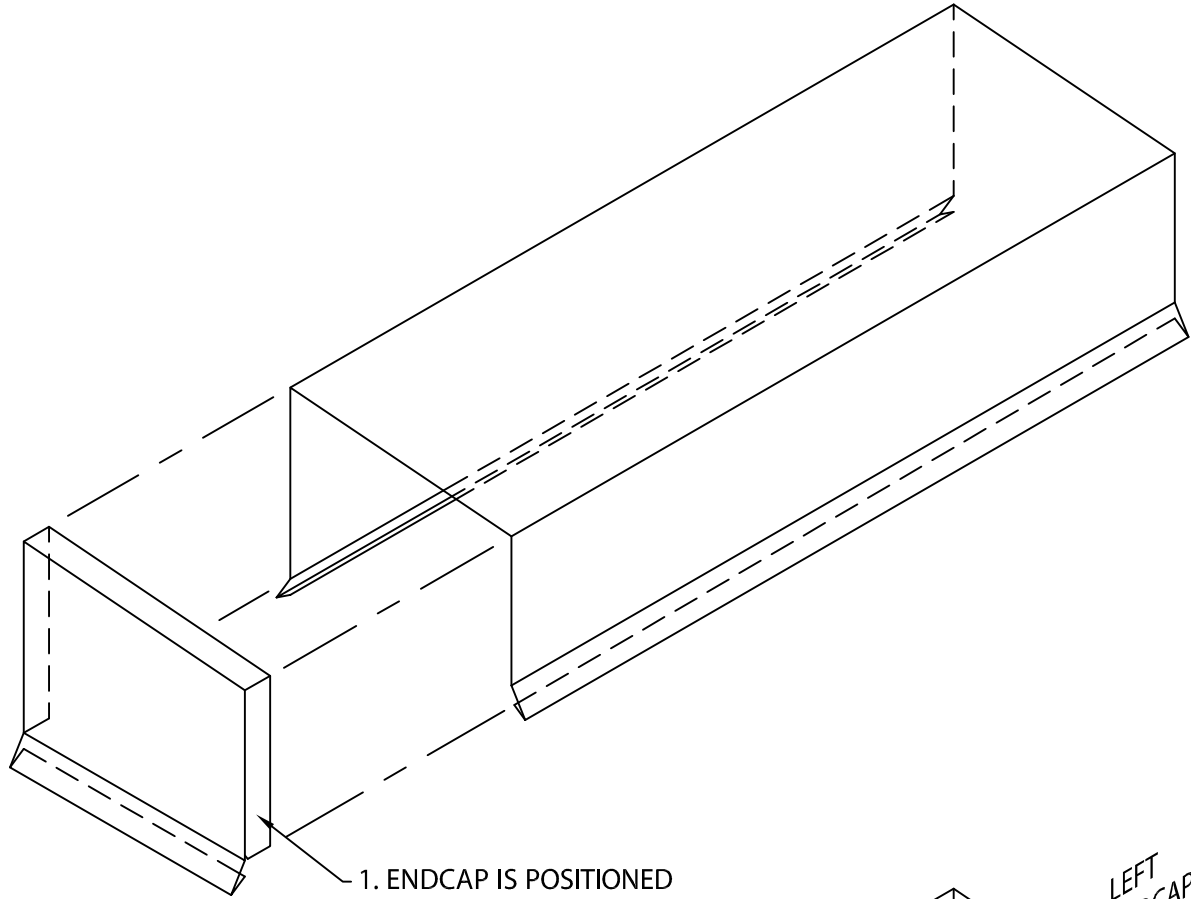

1. ENDCAP IS POSITIONED
INSIDE COPING AND TABS
ARE ALLIGNED WITH ALL SIDES

2. THE ENDCAP IS
QUICKLOCKED
INTO PLACE

OUTSIDE
FACE

NON-WELDED
ENDCAPS ARE
FABRICATED WITH
OPEN OUTSIDE
CORNERS

3. THE SEAMS ARE SEALED WITH
CAULK ALONG THE UNDERSIDE

LEFT
ENDCAP

INSIDE
FACE