

PAC-TITE WT CANTED FASCIA

GALVANIZED WATERDAM VERSION



SIZES

Face Heights

5 1/2"

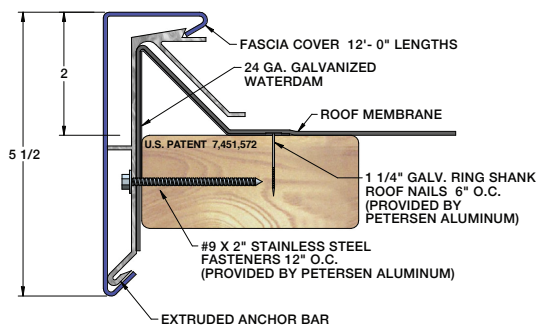

PRODUCT FEATURES

- ▶ Unique design keeps flange out of the waterline
- ▶ Extruded aluminum anchor bar securely terminates the membrane
- ▶ Unmatched uplift protection in roof edge applications
- ▶ Snap-On cover eliminates crimping
- ▶ Pre-punched holes for precise fastener placement
- ▶ Includes anchor bar EPDM splice plates and required fasteners
- ▶ Concealed splice plates allow for cleaner design
- ▶ Non-penetrating design eliminates need for stripping in/heat welding
- ▶ Superior watertight integrity of the installation
- ▶ Extensively tested to exceed industry standards
- ▶ Slotted holes allow for thermal movement
- ▶ Lifetime, 215 mph wind warranty available
- ▶ Wide variety of colors and finishes
- ▶ Convenient 12' Lengths
- ▶ Custom and radius capabilities available
- ▶ Reusable and recyclable for reinstallation

MATERIALS

- ▶ 15 Stocked PAC-CLAD Finishes (22 gauge steel)
- ▶ 29 Stocked PAC-CLAD Finishes (.050 aluminum)
- ▶ 6 Stocked PAC-CLAD Finishes (.063 aluminum)
- ▶ Mill Finish Aluminum (.050 & .063 aluminum)
- ▶ Clear and Colored Anodized (.050 & .063 aluminum)

ACCESSORIES

- ▶ Miters (90 Degrees and Non-90 Degrees)
- ▶ Scuppers (Downspout, Spillover and Overflow)
- ▶ Drainage Components

TESTING

- ▶ ANSI/SPRI/FM 4435 ES-1 Standard to comply with the International Building Code
- ▶ Factory Mutual approved

WARRANTY

A Lifetime 215 mph warranty is available. It covers replacement or repair of any portion of the roof edge system that has failed due to a defect in the supplied materials. The warranty covers the roof edge for the lifetime of the roof on which it was originally installed.