

TO : Petersen Aluminum Corporation  
10551 PAC Road  
Tyler, Texas 75707                      Attention : Mr. Josh Jacobi

FROM : Thomas M. Shingler, PE  
Licensed Structural Engineer  
Design Dynamics, Inc.

DATE : March 28, 2016

SUBJECT : ASTM E-1592  
HWP-16B Wall Panel  
1.371" dp. x 16" wide (nominal) x 24 ga. steel  
ASTM E-1592 Procedure for the Determination of Wind  
Negative Wind Load Capacity @ 1.33 ft. & 4.00 ft. Clip Spacings

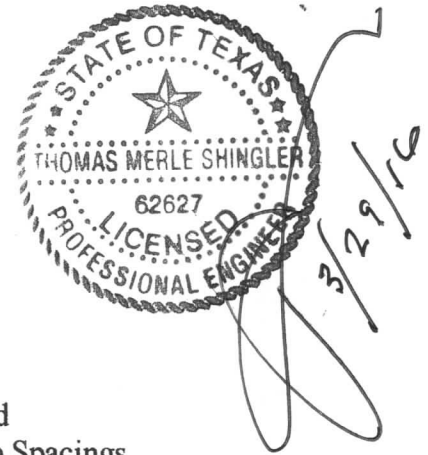

TEST PROCEDURE : ASTM E-1592  
STANDARD TEST METHOD FOR THE STRUCTURAL  
PERFORMANCE OF SHEET METAL ROOF AND SIDING  
SYSTEMS BY UNIFORM STATIC AIR PRESSURE

DIFFERENCE.

PURPOSE : To determine the Ultimate Wind Uplift Capacity of the submitted metal  
wall system when fastened at various clip spacings.

TEST DATE : March 14, 2016 (9 spans @ 1.33 ft. o/c)  
March 4, 2016 (3 spans @ 4.00 ft. o/c)

TEST SPECIMEN : HWP-16B Profile @ 1.371" dp. x 16" wide (nominal) x 24 ga. steel

TEST CHAMBER : Composed of a floor mounted reinforced wooden frame capped  
with a reinforced wood frame/purlin system designed to support  
the test specimen.  
The test pressures were applied to the specimen via a 4 mil plastic  
film designed to accurately configure to the panel profile and give  
both the panel shape and the sidejoint elements full degree of  
freedom during the loading process.

PURLIN MEMBERS : 16 ga. steel stud supports. Stud members were spaced at either 1.33 ft. or 4.00 ft. on centers and represent the minimum and maximum stud spacing extremes for the wall panel being tested.

PRESSURE INDICATOR : Extech Model HD700 Differential Pressure Manometer with a 0-2 psi (0-288 psf) range and a min/max “hold” feature which “locks” at the ultimate test pressure.

DIGIMATIC CALIPER : Honeywell Model Short Longfellow Linear Position Transducer with 0-6” of travel.

INSTALLATION : The system was inverted and panels were installed with one (1) piece stainless steel clips which were screw-attached to the top flanges of the 16 ga. steel stud members using two (2) #14-13 x 1 ½” long self drilling flat head, CONCEALOR fasteners. Sidejoints consisted of panel-to-panel longitudinal edge engaged male/female joint. Continuity fasteners were located at the top of the sidelap joints at panel ends. Transparent/flexible plastic film (Visqueen @ 4 mils thick) was applied loosely between panels and the top flange of the various 16 ga. stud members. This plastic film was also tucked into each panel sidejoint to create a vacuum seal, but not restrict sidejoint movement under load.

PROCEDURE : The individual panels were installed into the test chamber as a seven (7) panel wide array per standard field techniques. The specimen was checked for proper adjustment and all vents closed in the pressure measuring lines. The required deflection measuring apparatus’ were installed at their specified locations. These locations are illustrated on an enclosed sketch.

Initially the system was preloaded to (-) 5 psf to insure proper seating of the panels, clips and plastic film.

After the preloading process, initial deflection measurements were taken at the eight (8) key panel locations. These initial deflection readings represented the zero position/zero load specimen status from which all readings were referenced. Individual data sheets and graphic plots of the deflection readings are enclosed with this report.

A “step loading” procedure was used with load increments of 10 psf.

At each increment pressure level, the test pressure was maintained for a period of not less than sixty (60) seconds.

After the sixty (60) second pressure “hold” period, measurements were recorded at each of the eight (8) critical panel locations.

Also during this time period..... broad-flat areas of the panels, sidejoints and clips were visually inspected for signs of localized distress.

At the end of each pressure “hold” phase, the test chamber was returned to a zero pressure status and deflection measurements were once again recorded to check for meaningful “set” in the system.

Ever-increasing pressure values were applied and deflection values recorded both at the pressure as wells as at zero.

This product continued until the Ultimate Uplift Pressure of the panel or a panel system component demonstrated “distress”.

The Allowable Uplift Capacity for the tested system is the Ultimate Uplift Pressure divided by a Factor-of-Safety of 2.00.

The Allowable Uplift Pressure for the panel system established at both the 1.33 ft. and the 4.00 ft. stud spacing, with intermediate Allowable Uplift Pressures being determined via linear interpolation between the two (2) test-established extremes.

ASTM E-1592 TEST RESULTS :

Span, ft.	Ultimate Pressure, psf	Allowable Pressure, psf
1.33	(-) 162.6	(-) 81.3
4.00	(-) 74.1	(-) 37.1

ALLOWABLE WIND UPLIFT LOAD/SPAN CHART :

Panel Span, ft.	Allowable Wind Uplift Pressure, psf
1.33	(-) 81.3
1.67	(-) 75.8
2.00	(-) 70.3
2.33	(-) 64.7
2.67	(-) 59.2
3.00	(-) 53.7
3.33	(-) 48.2
3.67	(-) 42.6
4.00	(-) 37.1

General Notes :

1. The Allowable Pressure is the Ultimate Test Pressure divided by a Factor-of-Safety (Load Factor) of 2.00.
2. The published Allowable Wind Uplift Pressure considers panel buckling strength, sidejoint disengagement resistance and clip/sidejoint interactive strength only.
3. The clip-to-substrate fastener capacity must be investigated by a design professional and consider the clip pry coefficient where applicable.

\*\*\*\*\* END OF REPORT \*\*\*\*\*



# Farabaugh Engineering and Testing Inc.

Project No. T160-16

Report Date: March 24, 2016

Total Pages (inclusive): 19

**ASTM E1592**  
STANDARD TEST METHOD FOR  
STRUCTURAL PERFORMANCE OF SHEET METAL ROOF AND SIDING  
SYSTEMS BY UNIFORM STATIC AIR PRESSURE DIFFERENCE

**HWP SERIES PANEL**  
**HWP-16B WALL PANEL**

FOR

PETERSEN ALUMINUM CORP.  
10551 PAC ROAD  
TYLER, TX. 75707

Report Prepared By:

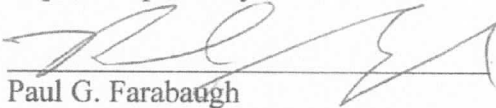
  
Paul G. Farabaugh

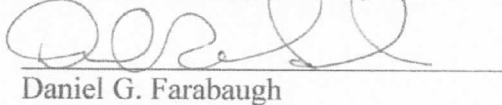

Reviewed and Approved By:

  
Daniel G. Farabaugh

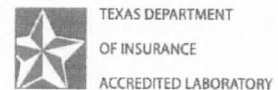
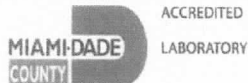

Project No. T160-16

**ASTM E1592-01**  
**STANDARD TEST METHOD FOR**  
**STRUCTURAL PERFORMANCE OF SHEET METAL ROOF AND SIDING**  
**SYSTEMS BY UNIFORM STATIC AIR PRESSURE DIFFERENCE**

**Purpose**

This test method covers the evaluation of the structural performance of Sheet Metal Panels and Anchor to Panel Attachments for roof or siding systems under uniform static air pressure difference.

**Test Date**

3/14/16 Test #1 - 9 spans @ 1'-4" o.c.

3/4/16 Test #2 - 3 spans @ 4'-0" o.c

**Test Specimen**

*Manufacturer.*                Petersen Aluminum  
   10551 PAC Rd.  
   Tyler, TX. 75707

Panel:                HWP-16B Wall Panel, 16"(nominal) Panel Width, 24 Ga. Steel

Panel Clip        20 ga. x 2.5" wide clip.

**Testing Apparatus**

A vacuum test chamber was used with two static pressure taps located at diagonally opposite corners. A controlled blower provided a vacuum to uniformly load the specimen mock-up. Calibrated manometers were used to measure the pressure at each pressure tap. The uniform load pressure was performed in the negative direction to monitor wind uplift on the panel specimen mock-up. Calibrated deflectometers were attached to monitor panel deformation as shown.

Project No. T160-16

### **Installation**

- The panels were installed on to 16 ga supports with the 20 ga. clips using #14 - 13 x 1-1/2" long self drill, flat head, Concealor fasteners (2 fasteners per clip). Continuity fasteners were located at the top of the sidelap joints at panel ends.
- Plastic (4 mil thick) was employed loosely between the panels and subgirts and in the side joints to create a vacuum seal.

### **Procedure**

- The specimen was checked for proper adjustment and all vents closed in the pressure measuring lines.
- The required deflection measuring apparatus' were installed at their specified locations.
- A nominal initial pressure was applied equal to at least four times but not more than ten times the dead weight of the specimen. This nominal pressure was used as the reference zero and initial deflection readings were recorded.
- At each load increment, pressure was maintained for a period of not less than 60 seconds and until the deflection gages indicated no further increase in deflections.
- Successive increments were achieved as above until failure or ultimate load was reached.

The test was conducted according to the procedure in ASTM E-1592-01 and as noted herein. In our opinion the tape and plastic had no influence on the results of the test.

Project No. T160-16

## TEST #1

Specimen: HWP-16B Wall Panel, 16"(nominal) Panel Width, 24 Ga. Steel

Clip Spacing: 1'- 4" o/c

### NEGATIVE (UPLIFT) TEST PRESSURE

PAC HWP-16B PANEL 16"W X 24GA. STEEL (SPECIMEN A) 9 SPANS @ 1'-4" oc

DEFLECTION DIAL READINGS (INCHES)									
LOAD (PSF)	D-1	D-2	D-3	D-4	D-5	D-6	D-7	D-8	REMARKS
1.3	0	0	0	0	0	0	0	0	0 PANEL WT.
16.9	0.092	0.456	0.087	0.493	0.065	0.438	0.065	0.431	
1.3	0.018	0.087	0.022	0.105	0.012	0.074	0.014	0.089	PANEL WT.
32.5	0.197	0.893	0.173	0.941	0.148	0.853	0.144	0.824	
1.3	0.037	0.199	0.042	0.257	0.027	0.182	0.03	0.203	PANEL WT.
48.2	0.287	1.248	0.251	1.333	0.229	1.212	0.225	1.201	
1.3	0.064	0.373	0.068	0.432	0.052	0.354	0.056	0.382	PANEL WT.
63.8	0.418	1.668	0.359	1.784	0.354	1.606	0.323	1.591	
1.3	0.111	0.624	0.109	0.719	0.098	0.604	0.1	0.643	PANEL WT.
79.4	0.589	2.096	0.512	2.226	0.531	2.055	0.457	1.993	
1.3	0.211	0.952	0.183	1.07	0.2	0.925	0.186	0.976	PANEL WT.
95.0	0.773	2.446	0.674	2.585	0.697	2.45	0.636	2.391	
1.3	0.354	1.324	0.301	1.456	0.35	1.294	0.323	1.368	PANEL WT.
110.6	0.954	2.665	0.826	2.895	0.911	2.744	0.853	2.767	
1.3	0.524	1.692	0.431	1.798	0.521	1.675	0.479	1.753	PANEL WT.
126.2	1.141	2.854	0.993	3.13	1.116	2.952	1.049	3.039	
1.3	0.671	1.985	0.571	2.079	0.716	1.967	0.651	2.056	PANEL WT.

### RESULTS:

Maximum Test Load (held for 1 min.) = 157.4 psf \* (No Failure)

Ultimate Test Load = 162.6 psf \* (Panel Seam Disengagement )

\* Includes panel dead load.



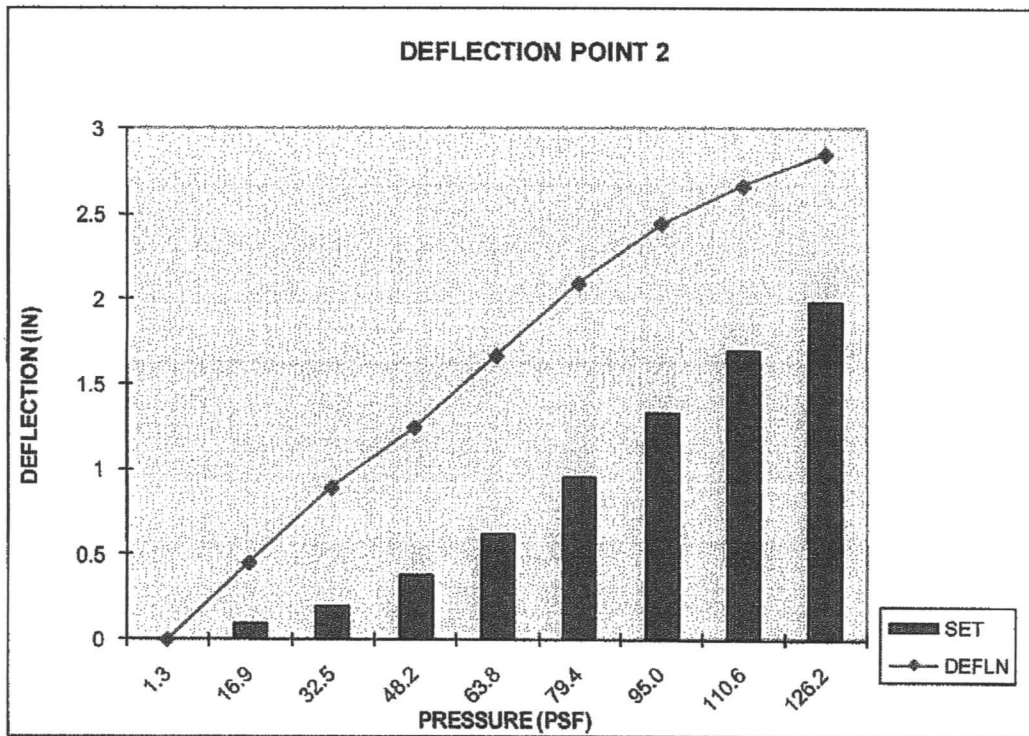
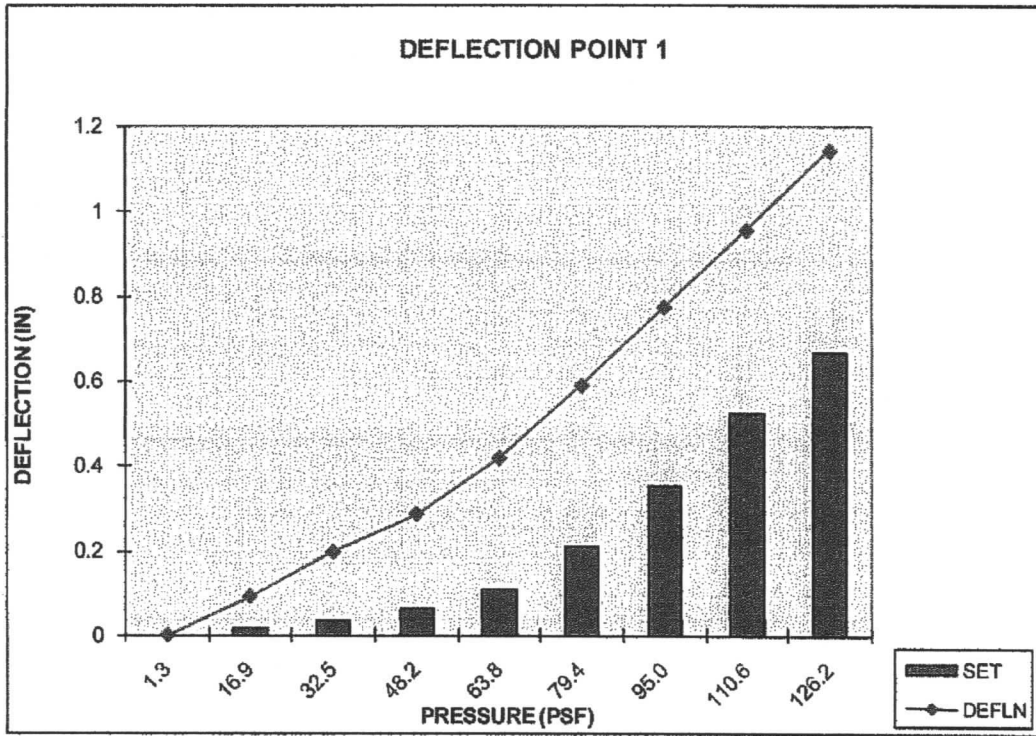

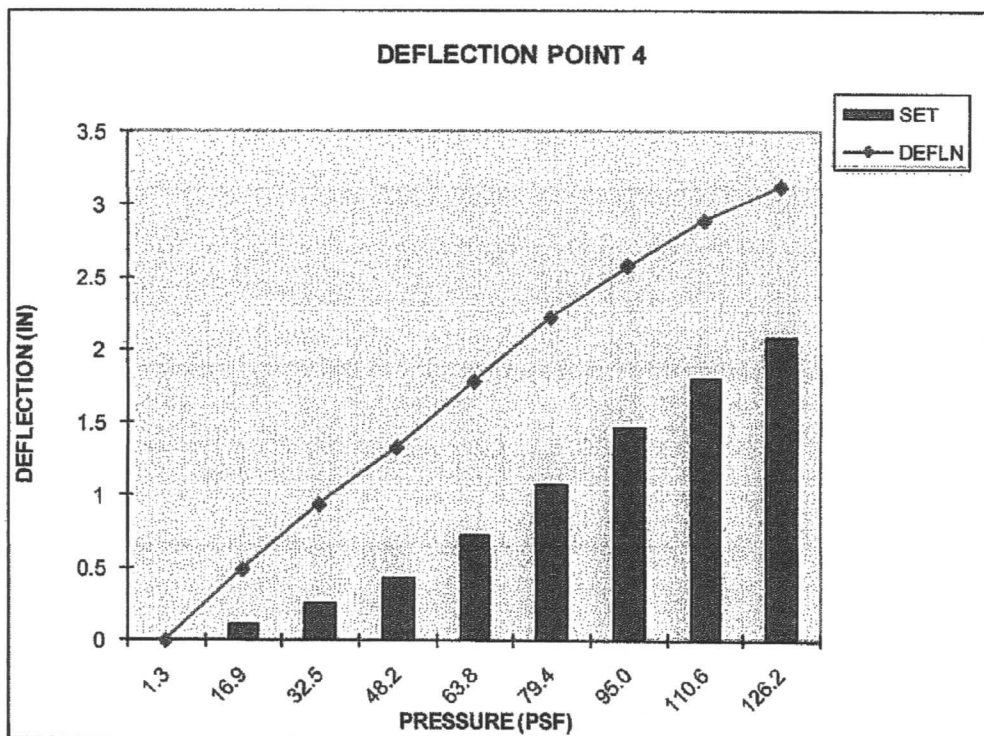
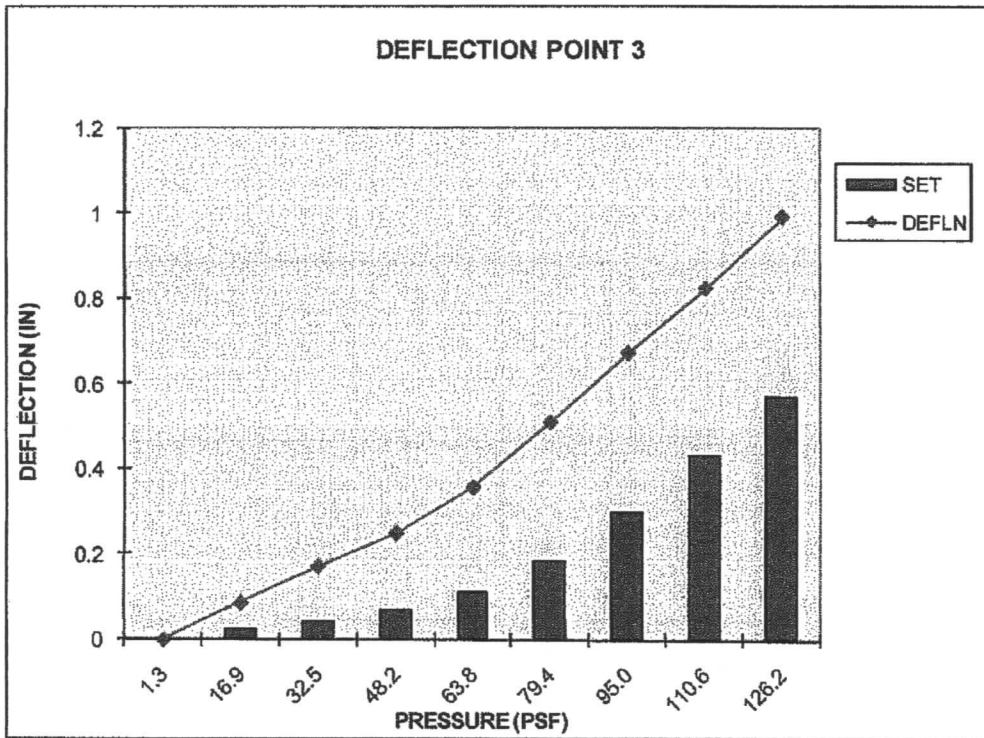

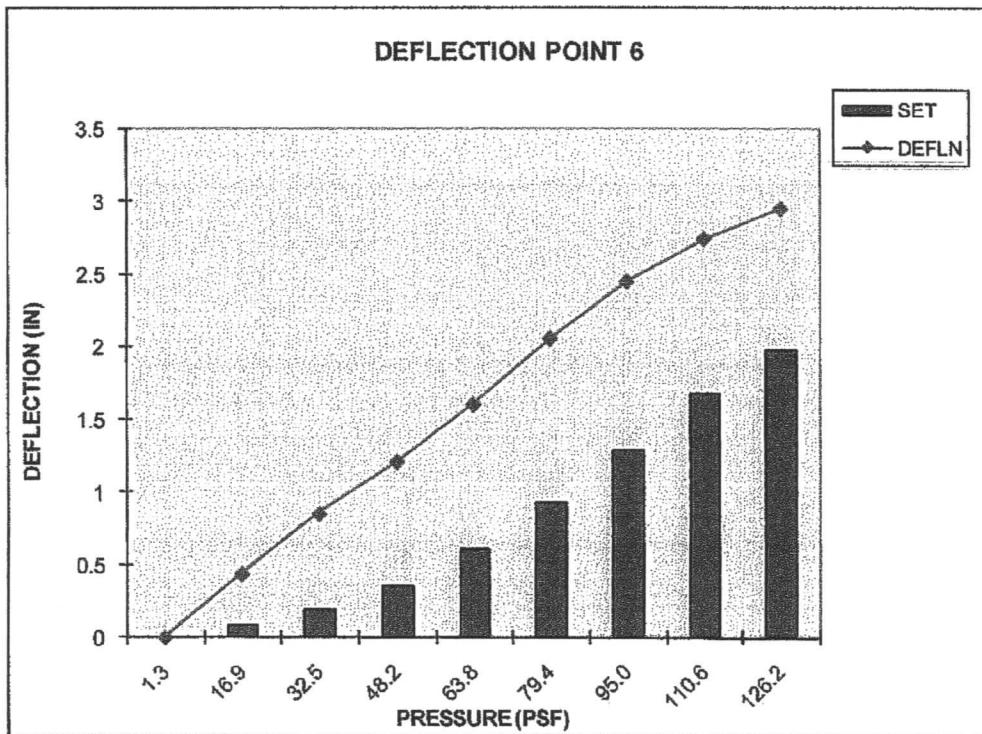
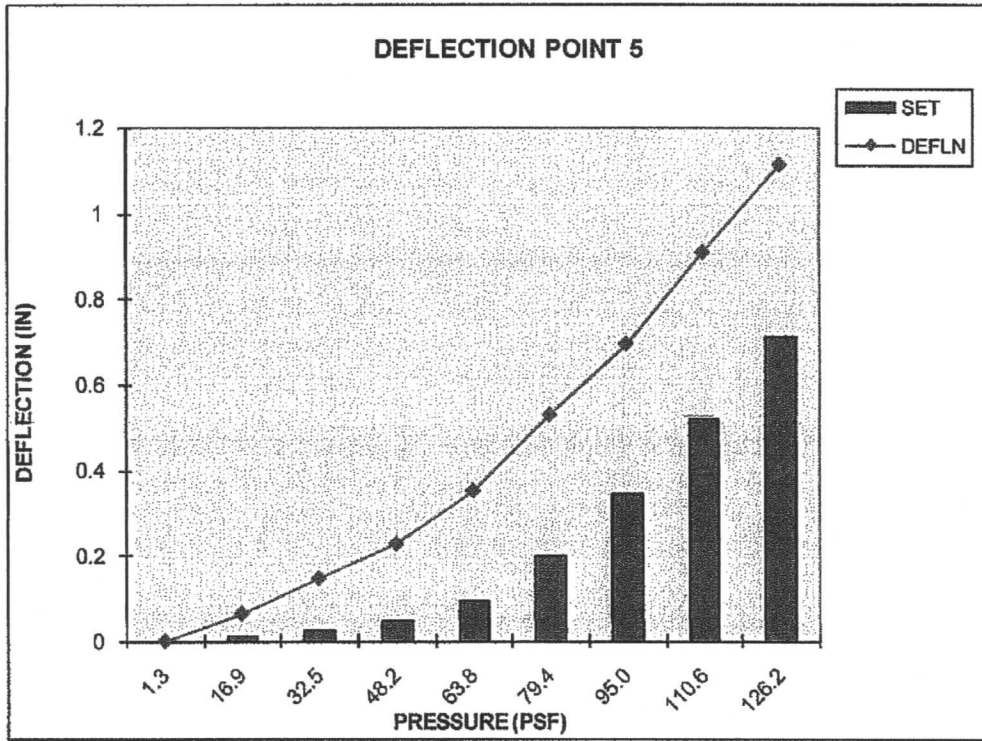

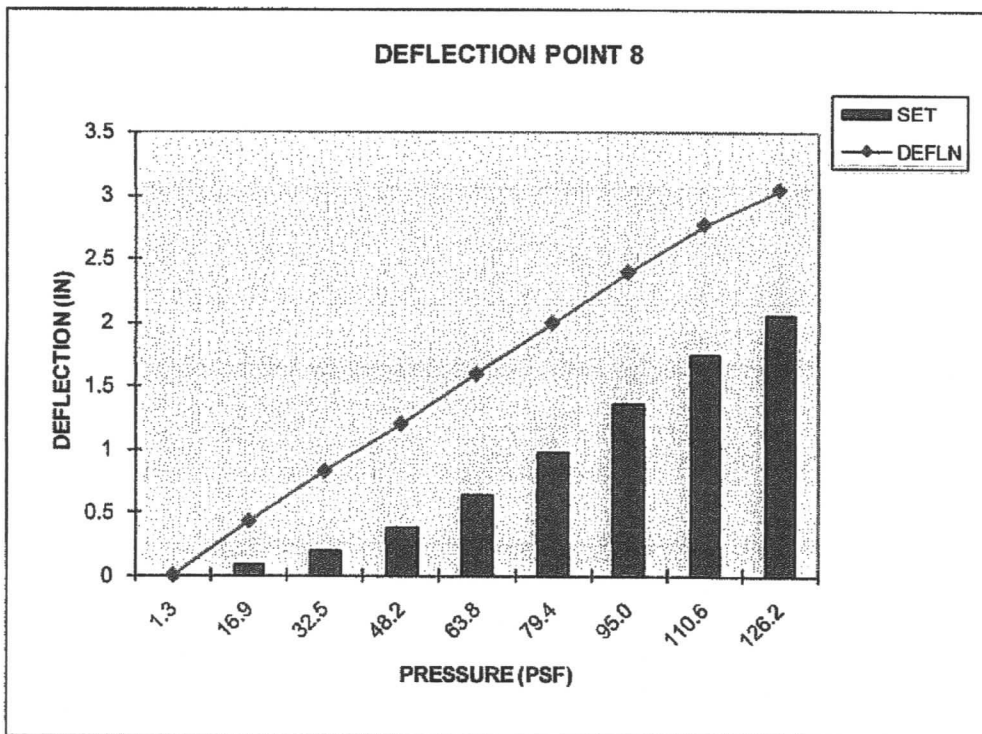
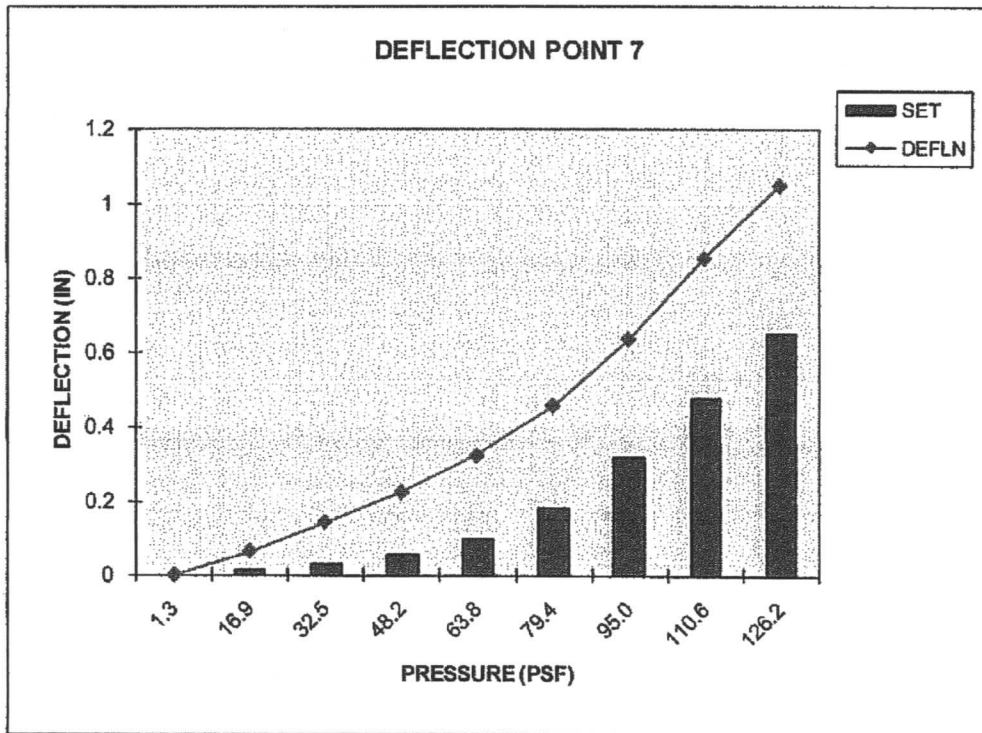

# TEST #1

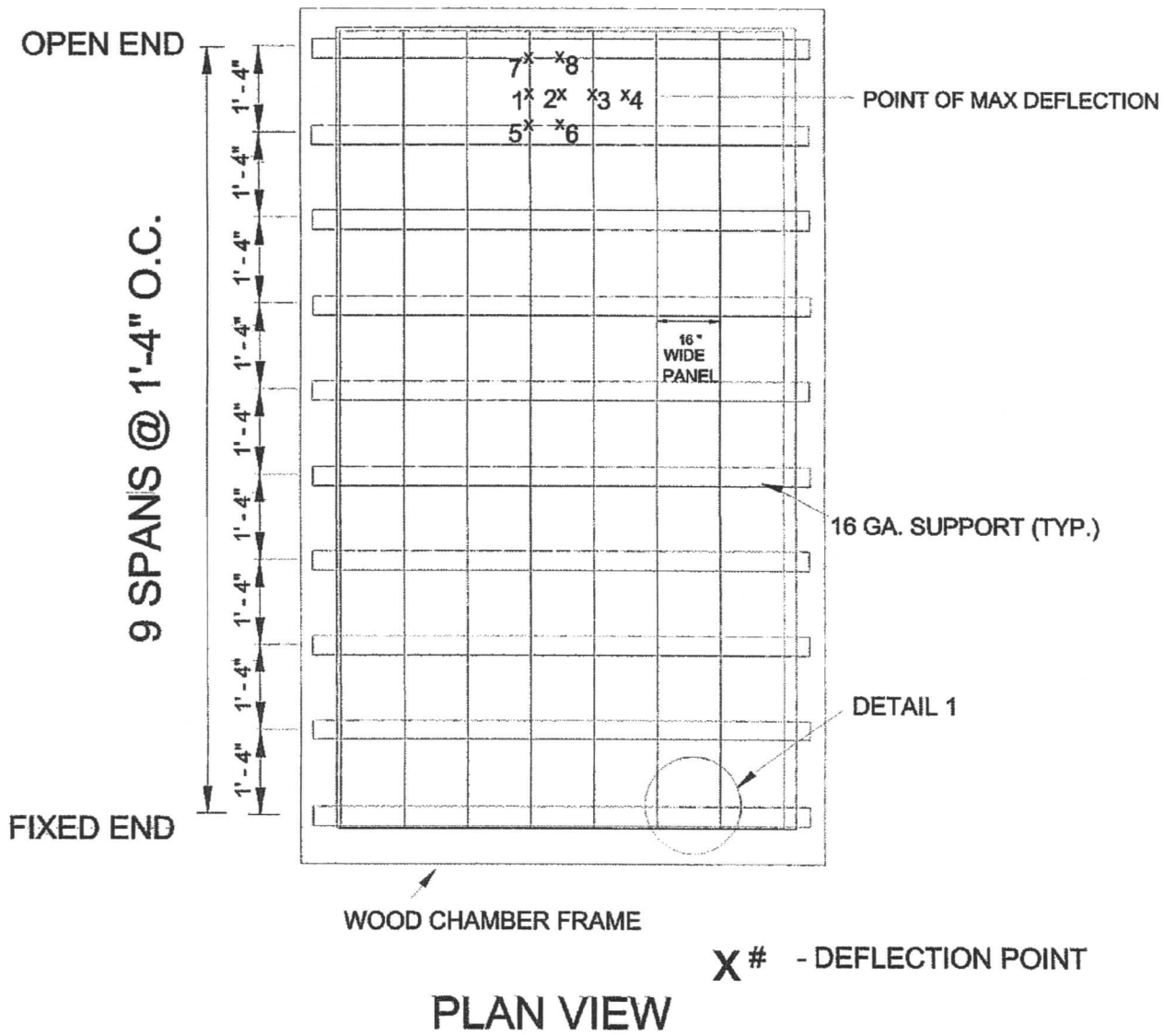

Project No. T160-16

## TEST #2

Specimen: HWP-16B Wall Panel, 16"(nominal) Panel Width, 24 Ga. Steel

Clip Spacing: 4 ft o/c

### NEGATIVE (UPLIFT) TEST PRESSURE

PAC HWP-16B PANEL 16"W X 24GA. STEEL (SPECIMEN B) 3 SPANS @ 4'-0" oc

LOAD (PSF)	DEFLECTION DIAL READINGS (INCHES)								REMARKS
	D-1	D-2	D-3	D-4	D-5	D-6	D-7	D-8	
1.3	0	0	0	0	0	0	0	0	0 PANEL WT.
11.7	0.137	0.383	0.123	0.368	0.091	0.386	0.064	0.352	
1.3	0.008	0.011	0.003	0.015	0.003	0.009	0.003	0.01	PANEL WT.
16.9	0.214	0.576	0.196	0.556	0.148	0.572	0.107	0.554	
1.3	0.012	0.041	0.012	0.047	0.008	0.035	0.01	0.05	PANEL WT.
22.1	0.318	0.81	0.309	0.795	0.239	0.792	0.155	0.745	
1.3	0.039	0.101	0.044	0.118	0.029	0.089	0.023	0.113	PANEL WT.
27.3	0.436	1.031	0.428	1.011	0.347	1.009	0.213	0.947	
1.3	0.084	0.175	0.088	0.202	0.082	0.172	0.042	0.188	PANEL WT.
32.5	0.55	1.229	0.533	1.221	0.452	1.226	0.28	1.16	
1.3	0.144	0.289	0.148	0.305	0.142	0.273	0.071	0.301	PANEL WT.
43.0	0.801	1.539	0.786	1.643	0.666	1.668	0.449	1.57	
1.3	0.273	0.5	0.273	0.511	0.25	0.495	0.166	0.514	PANEL WT.
53.4	1.033	1.969	1.027	2.026	0.879	2.058	0.621	1.939	
1.3	0.414	0.748	0.411	0.749	0.363	0.743	0.279	0.748	PANEL WT.
63.8	1.244	2.291	1.246	2.324	1.06	2.398	0.766	2.851	
1.3	0.551	0.996	0.55	0.989	0.49	0.998	0.392	0.981	PANEL WT.

### RESULTS:

Maximum Test Load (held for 1 min.) = 68.9 psf \* (No Failure)

Ultimate Test Load (failure) = 74.1 psf \* (Panel Seam disengagement)

\* Includes panel dead load.

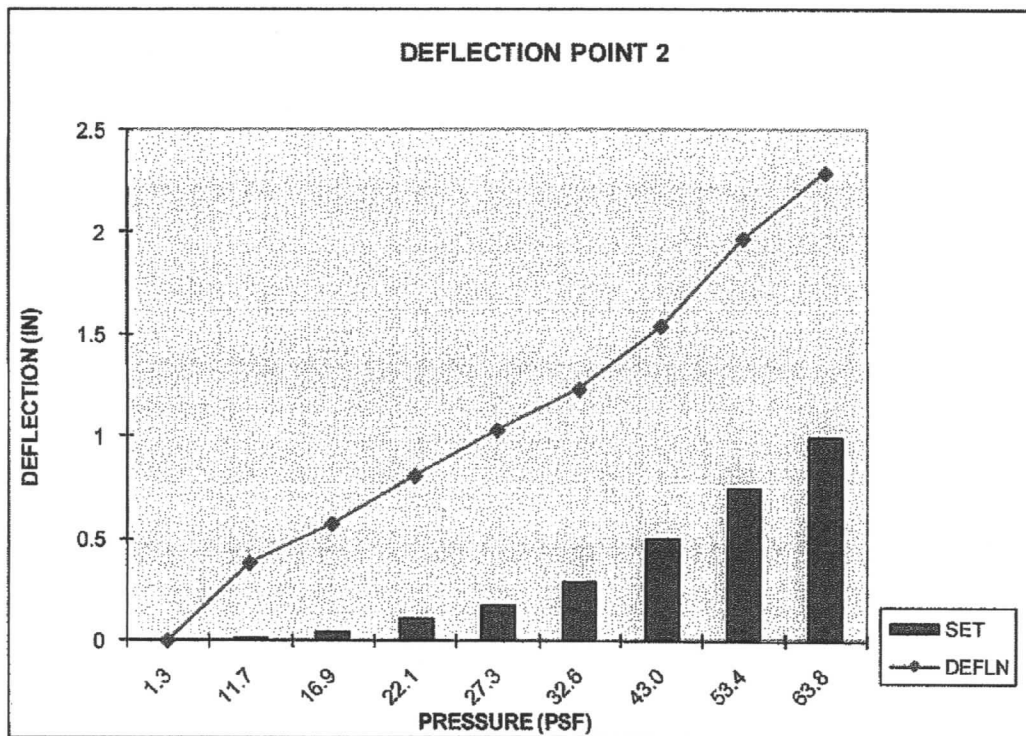
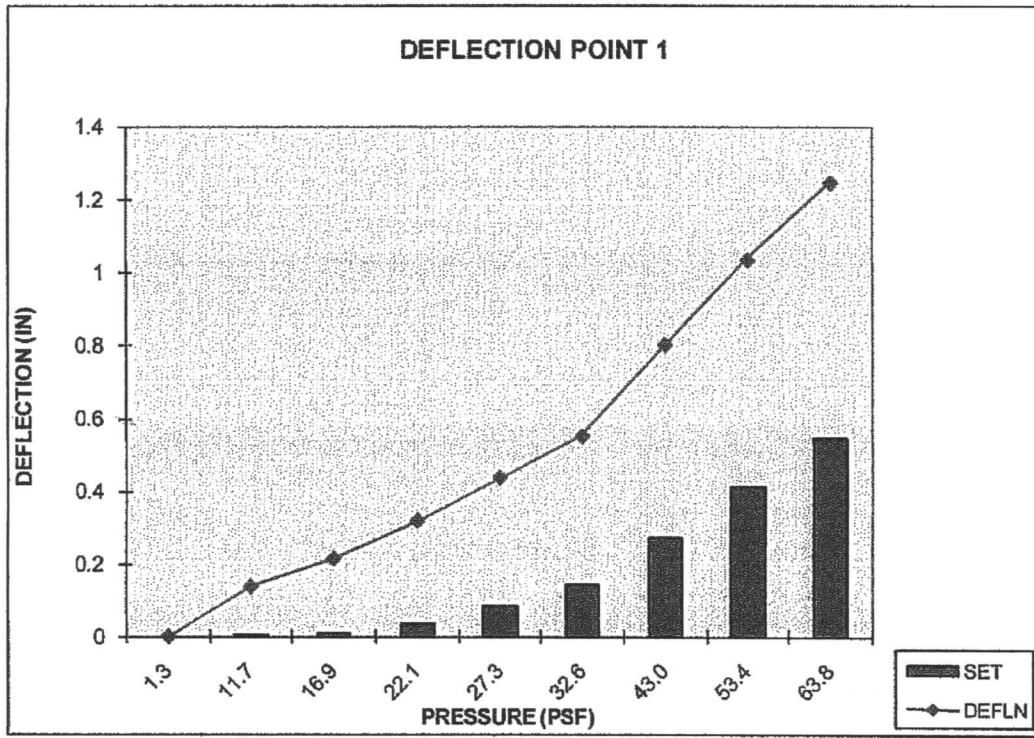

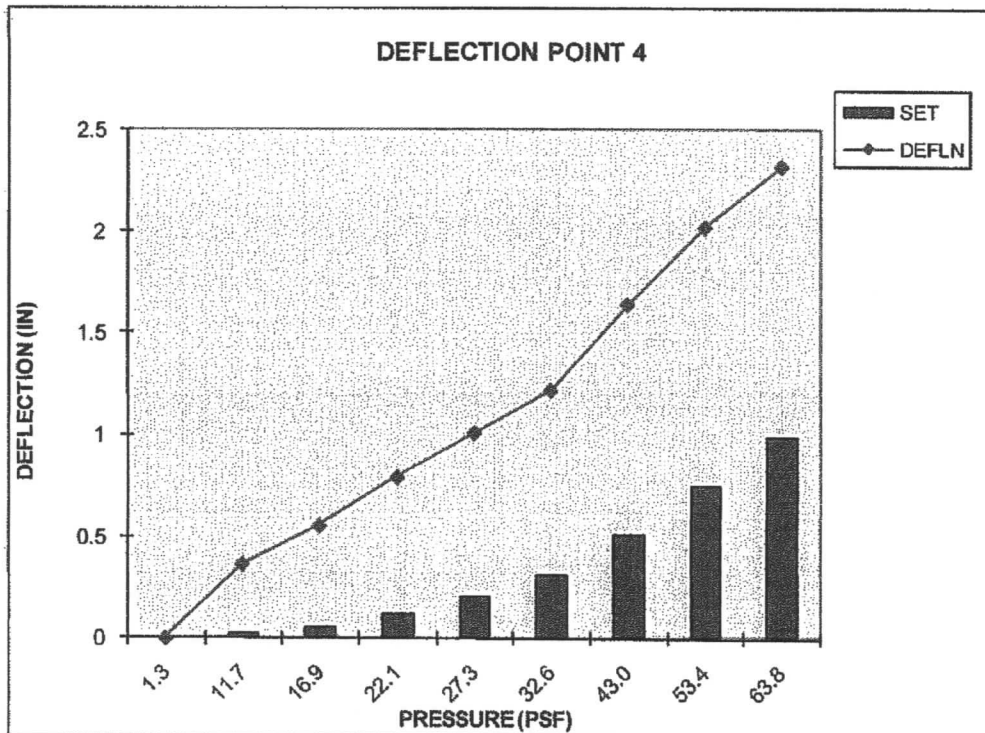
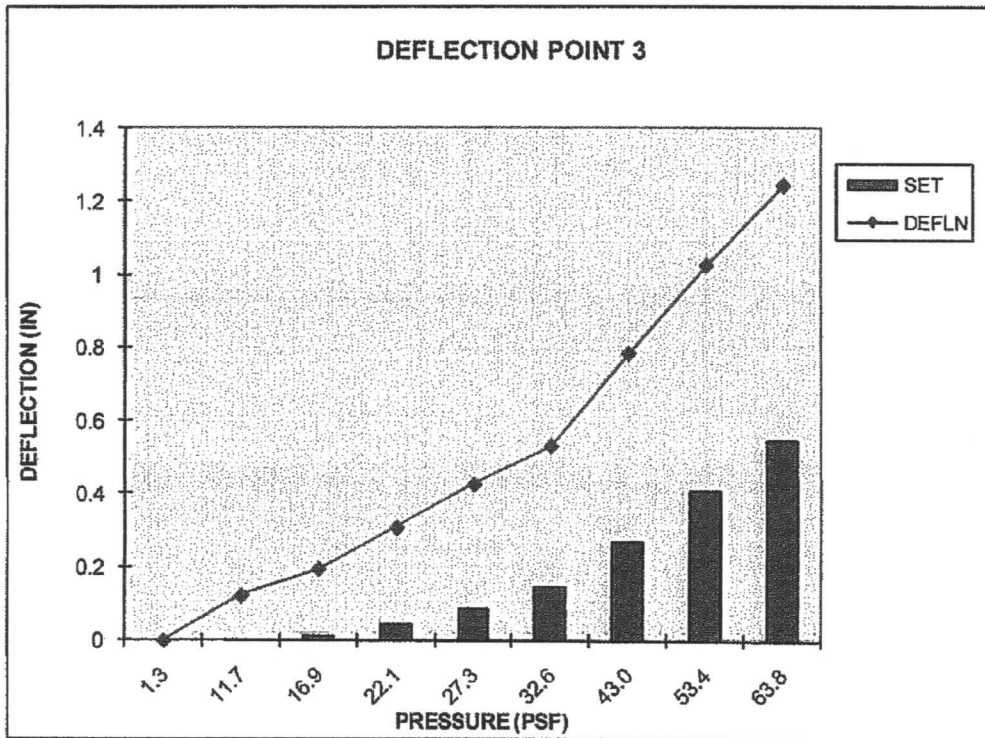



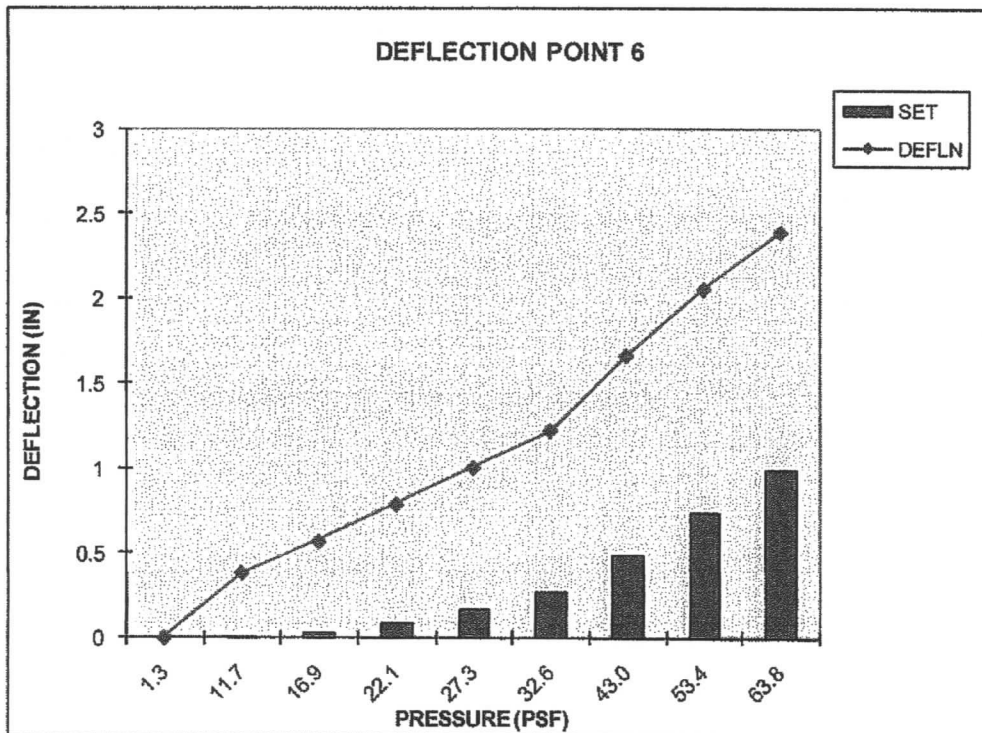
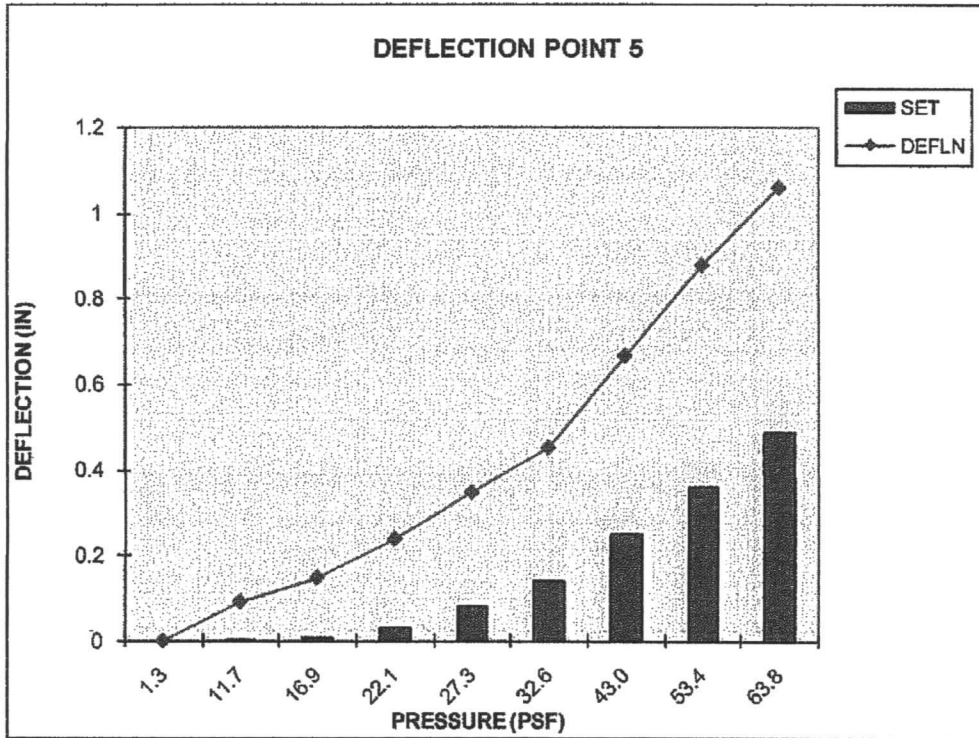

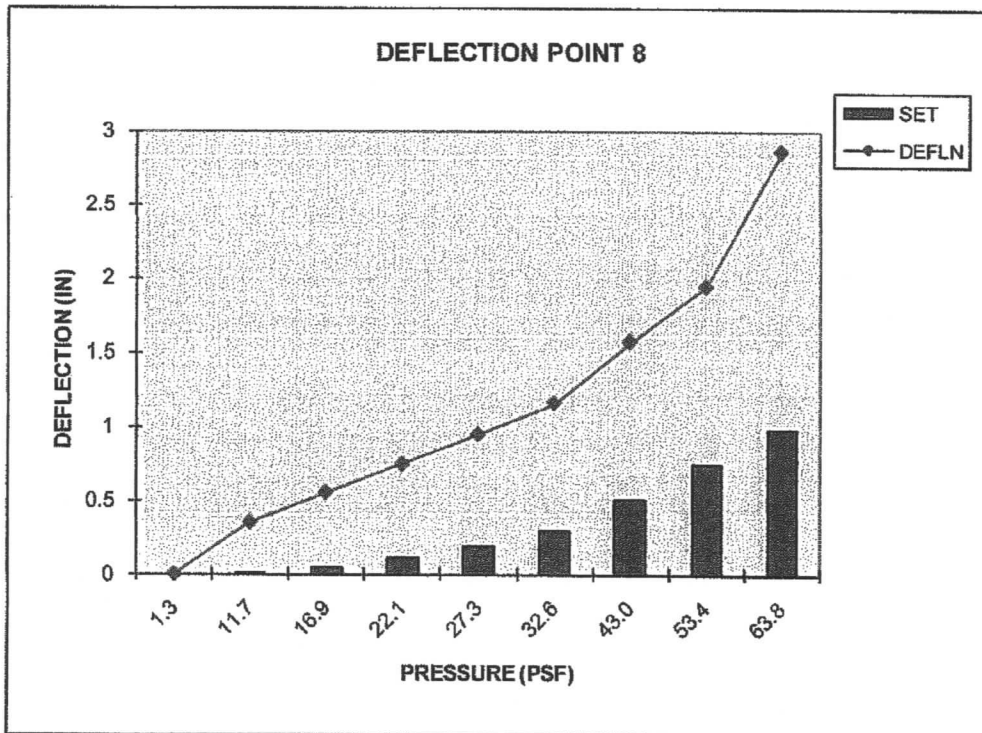
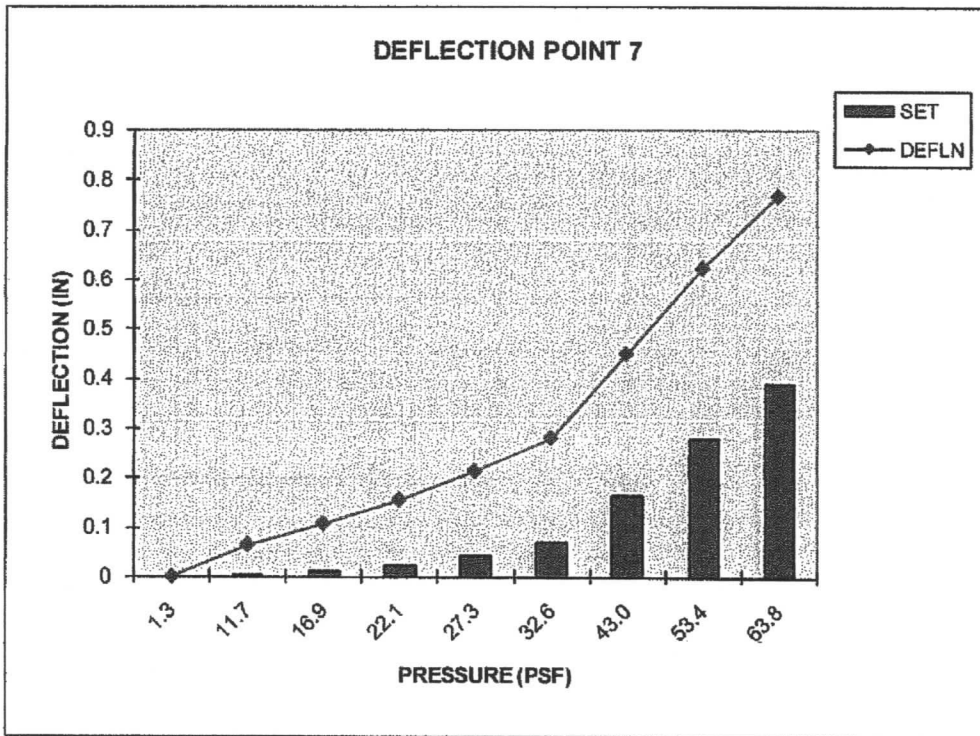

# TEST #2

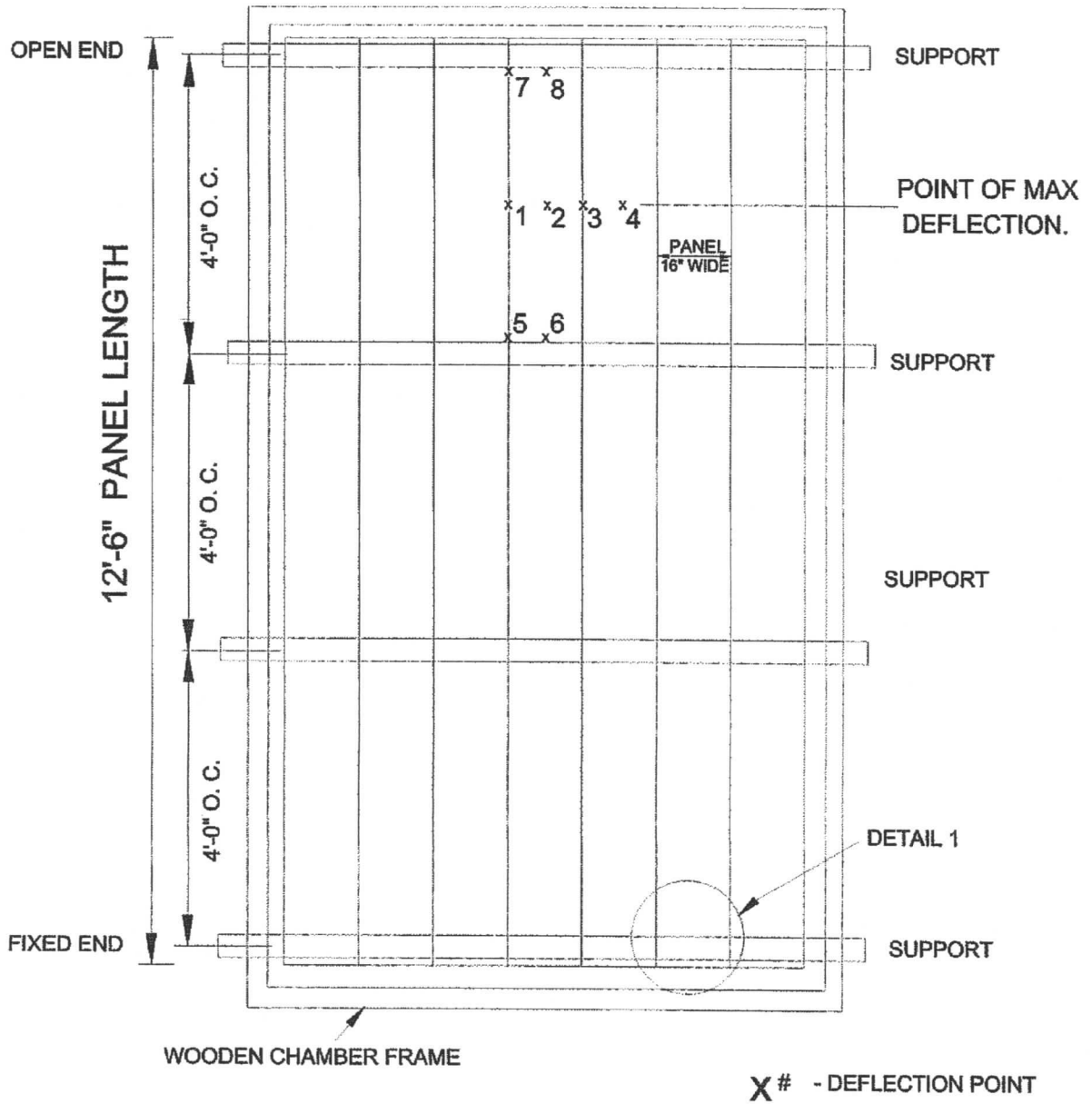

## PLAN VIEW

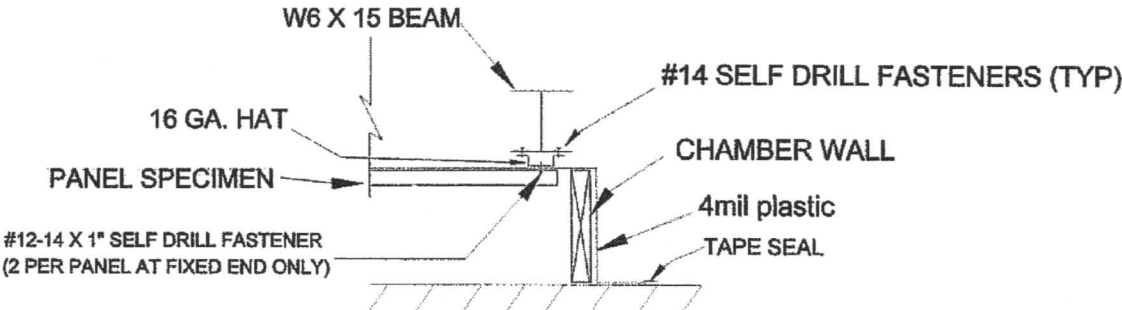

# DETAIL 1

Project No. T160-16

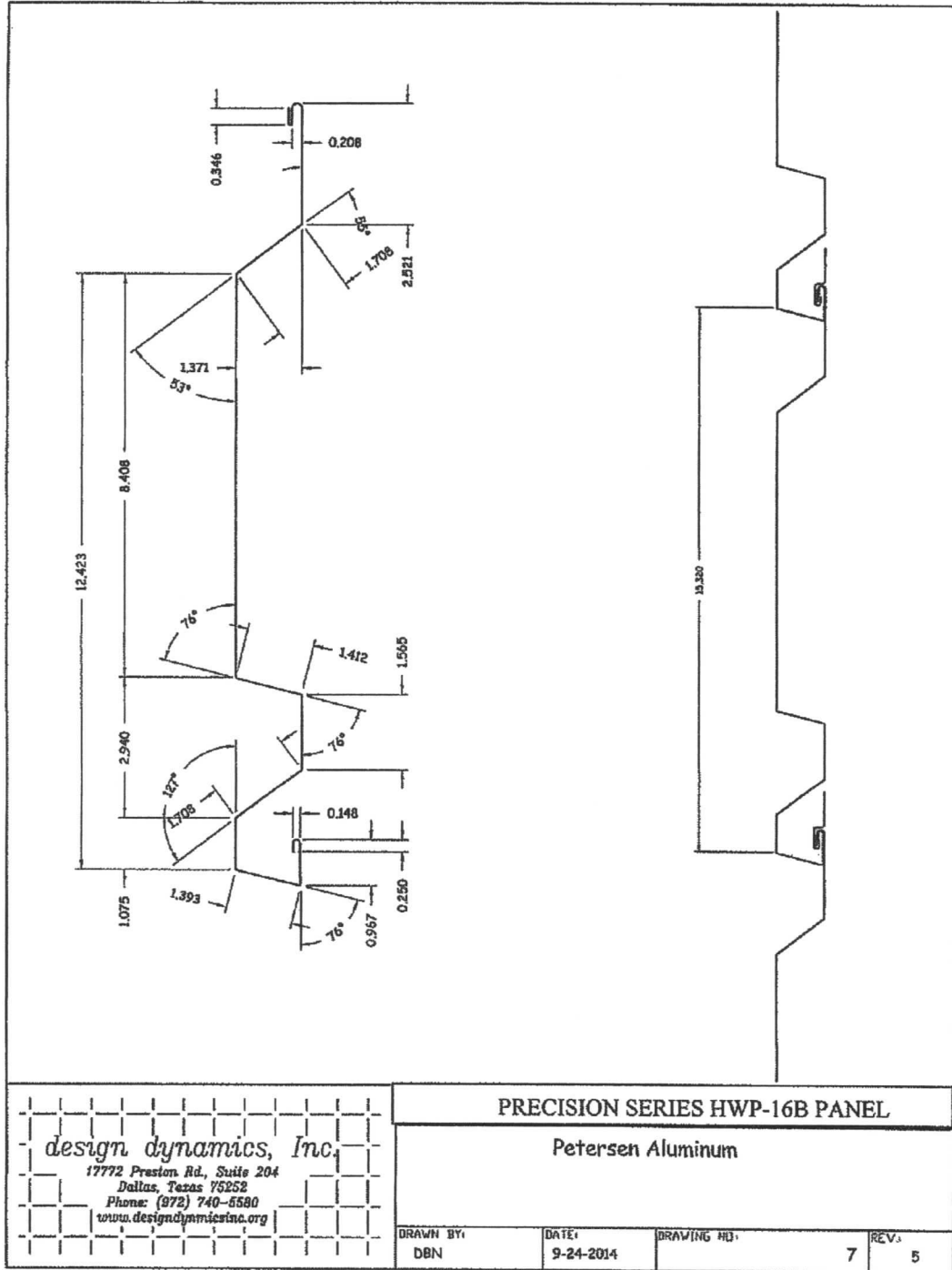

**CUSTOMER APPROVAL:**  
 My signature on this print indicates approval of all the information shown (or as amended hereon) and that items made to these specifications will be accepted

NAME: [Signature] (Tom. Adolph)  
 DATE: 4/12/11

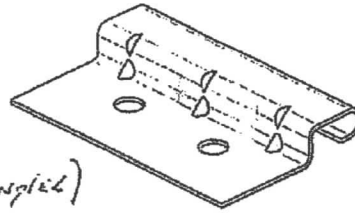

Isometric view  
 Scale: 1:1

METRIC UNITS (mm)	
Major	10
Minor	0.5

TOLERANCE (unless otherwise noted)	
Dimensions	FRACTIONAL
Dimensions	DECIMAL
Angles	DECIMAL
Surface Finish	RA
Position	AS SHOWN
Form	AS SHOWN
Fit	AS SHOWN
Thread	AS SHOWN

ENGLISH UNITS (Inches)	
Major	1/16
Minor	1/32

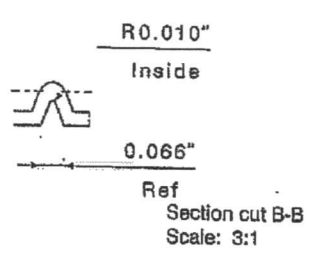
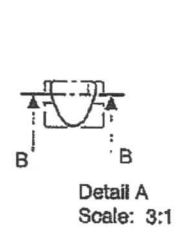
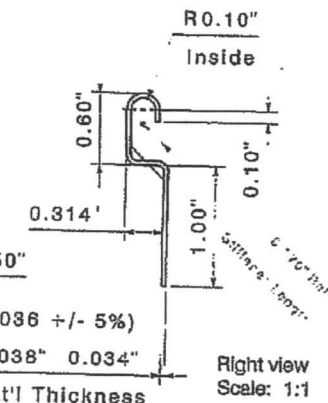
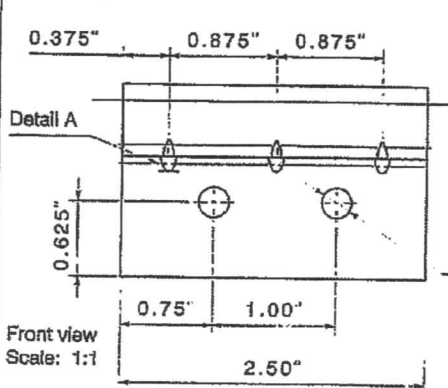

COMMERCIALITY AGREEMENT  
 THIS DRAWING CONTAINS INFORMATION THAT IS THE PROPERTY OF SFS INTEC, INC. THIS DRAWING MAY NOT BE REPRODUCED, COPIED, OR REPRODUCED, FOR DISTRIBUTION TO OTHER PARTIES WITHOUT WRITTEN CONSENT.

Material: G-90 Galv	Material Spec: Commercial Quality	 P.O. Box 8236 Woodbury, PA 19810 T. 610.376.5751 F. 610.376.0832	Description: Petersen Horizontal Wall Panel Clip
Surface Treatment:	Performance:		Drawing No.: XP-1006
Scale:	As Shown Above	Drawn By: scda	Date: 4/15/2011

Project No. T160-16

## TENSILE TEST REPORT

Client: Petersen Aluminum  
10551 PAC Rd.  
Tyler, TX. 75707

Test Date: 3-24-16

Test Method: ASTM A370-10

Material Description: HWP-16B Wall Panel, 16"(nominal) Panel Width, 24 Ga. Steel

Sample No.	Width (in)	Thickness (in)	Yield Load (lb)	Max. Load (lb)	0.2% Offset Yield Strength (psi)	Tensile Strength (psi)	Elongation (% in 2 inches)
0015-16	0.504	0.023	528.5	684.4	45,596	59,039	29.66

Equipment Used: Tensile Machine #QT7-061196-020  
Caliper #1074379  
Extensometer #10311744D  
Micrometer #110596927