

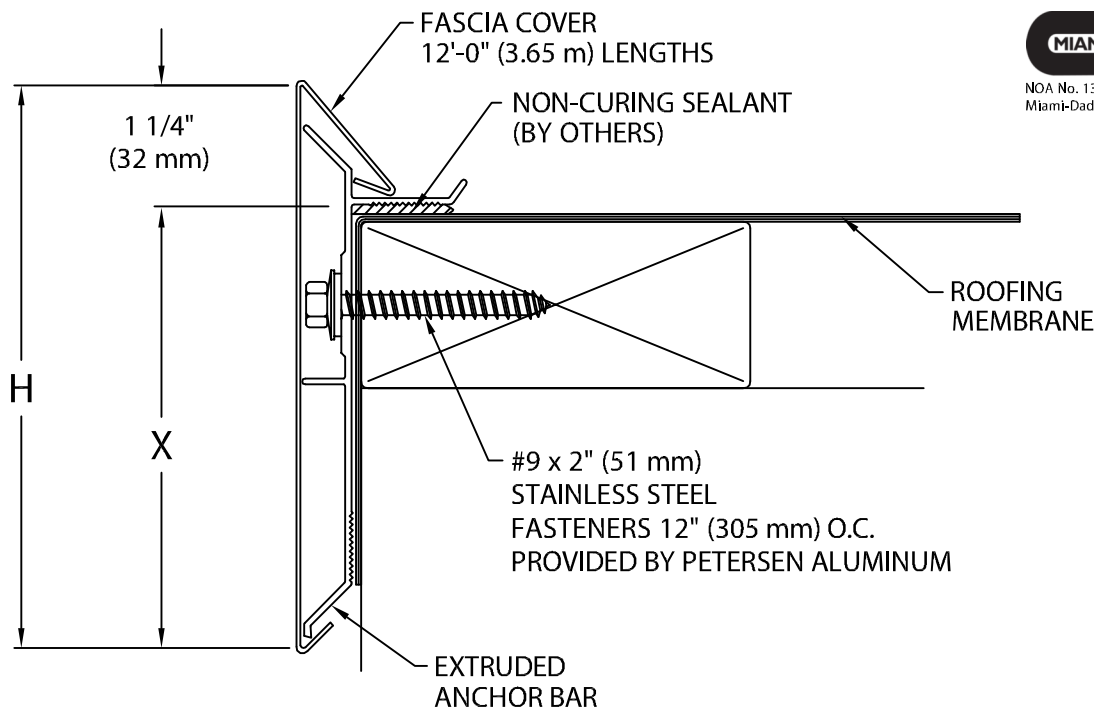

PAC-TITE ANGULAR FASCIA

FULLY ADHERED OR MECHANICALLY ATTACHED SINGLE-PLY VERSION

ANSI/SPRI ES-1 DESIGN PRESSURE OF 290 psf



Fascia is to be installed per Specifications and Petersen Aluminum's Installation Instructions Dwg. # 41110-12100

PAC-TITE ANGULAR FASCIA DIMENSIONS

PRODUCT ID. NO.	H DIM	X DIM	NAILER COVERAGE
<input type="checkbox"/> AF-40	4" (102 mm)	2 3/4" (70 mm)	1 NAILER
<input type="checkbox"/> AF-55	5 1/2" (140 mm)	4 1/4" (108 mm)	2 NAILERS
<input type="checkbox"/> AF-70	7" (178 mm)	5 3/4" (146 mm)	3 NAILERS
<input type="checkbox"/> AF-85	8 1/2" (216 mm)	7 1/4" (184 mm)	4 NAILERS

MATERIAL:

___ 24 Ga. (.65 mm) Galv. Steel

___ .040" (1.01 mm) Aluminum

___ OTHER _____

Color: _____

Finish: _____

Fabrication will proceed only after receipt of signed print approval.

Print Approval:

Architect and/or contractor shall verify all dimensions, sizes and quantities. All products to be installed in strict accordance with Petersen Aluminum's printed instructions.

Approved by: _____

Date: _____

QUANTITIES:

_____ Lineal Feet (12'-0" (3.65 m) Lengths)

_____ Outside Miters @ (_____)°

_____ Inside Miters @ (_____)°

_____ Overflow Scupper Style ___A___B

_____ Spillout Scupper Style ___A___B

_____ Downspout Scupper Style ___A___B

(___X___) Size A: Tapered 1 1/2" (38 mm) Drop
B: Flat

PROJECT:

ARCHITECT:

ROOFING CONTRACTOR:

REPRESENTATIVE/DISTRIBUTOR:



Phone: 800-323-1960 Fax: 800-722-7150

www.pac-clad.com

e-mail: info@pac-clad.com

DATE: 12/17/13

DRN BY: JJC

CKD BY: SAK

SHT.# ___ OF ___

DWG# 41010-12099

C